

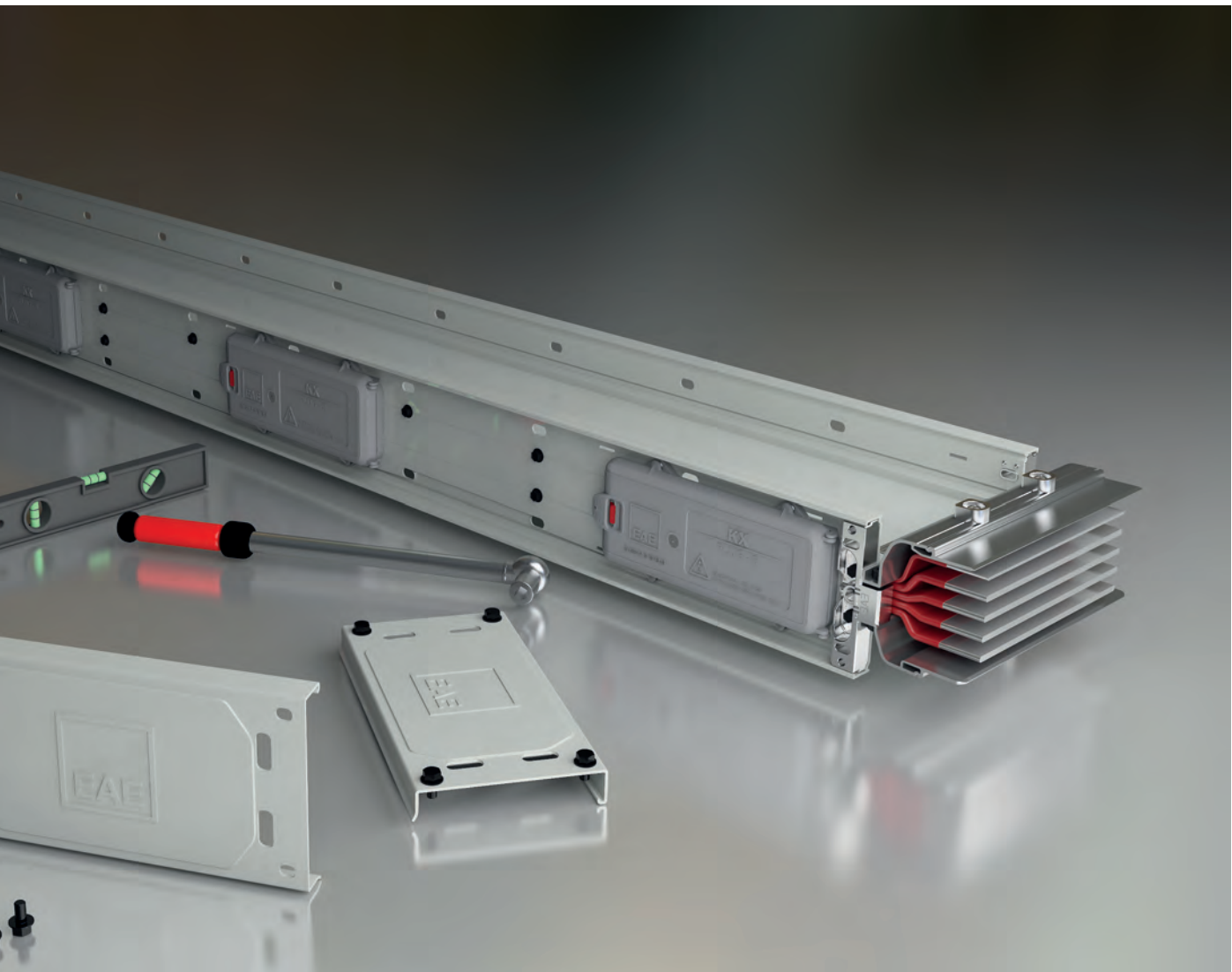

# E-LINE KX-III

Busbar Systems 400...6000A



# E-LINE KX-III



# CONTENTS

---

## ►► E-LINE KX-III

Introduction.....	2-3
Distribution & Horizontal Applications.....	4
Riser & Vertical Applications.....	5
Technical Characteristics.....	6-9
Order Code System.....	10
Straight Lengths.....	11
Elbows.....	12-15
Standard Components.....	16-17
Expansions.....	18-19
End Closer.....	20
Panel Connections.....	21-25
Transformer Connections & Flexible.....	26-30
Vertical & Horizontal Support Applications.....	31-32
Fixing Elements.....	33-41
Joint Structure.....	42
Measuring a Special Length.....	43
Inserting "Make-up Section".....	44
Certificates.....	45
Product Specification.....	46



# ELINEKX-III



## ►► Introduction



Tin plating is EAE standard application on all busbar systems. Silver plating is optional. Tin / Silver plating, prevents oxide formation on all contact surfaces and minimizes contact resistance.

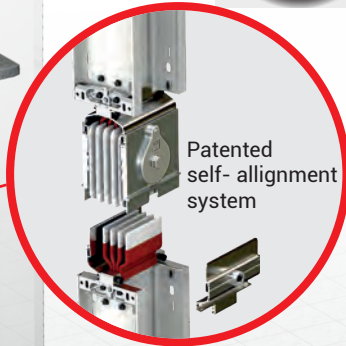

Patented self-alignment system



KX Busbar is easier to handle and install, saves labor costs and installation time.



Single-bolt connection includes special EAE belleville spring washer, that retains its original contact pressure ensuring proper electrical contact. Offers securer, more reliable and maintenance-free joint.

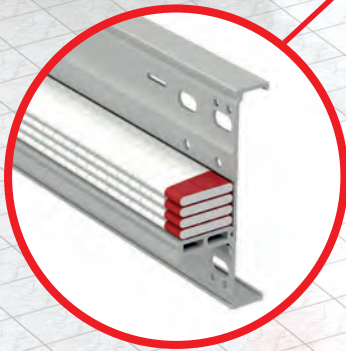

Specially formulated class B epoxy insulation ensures longer life cycle.

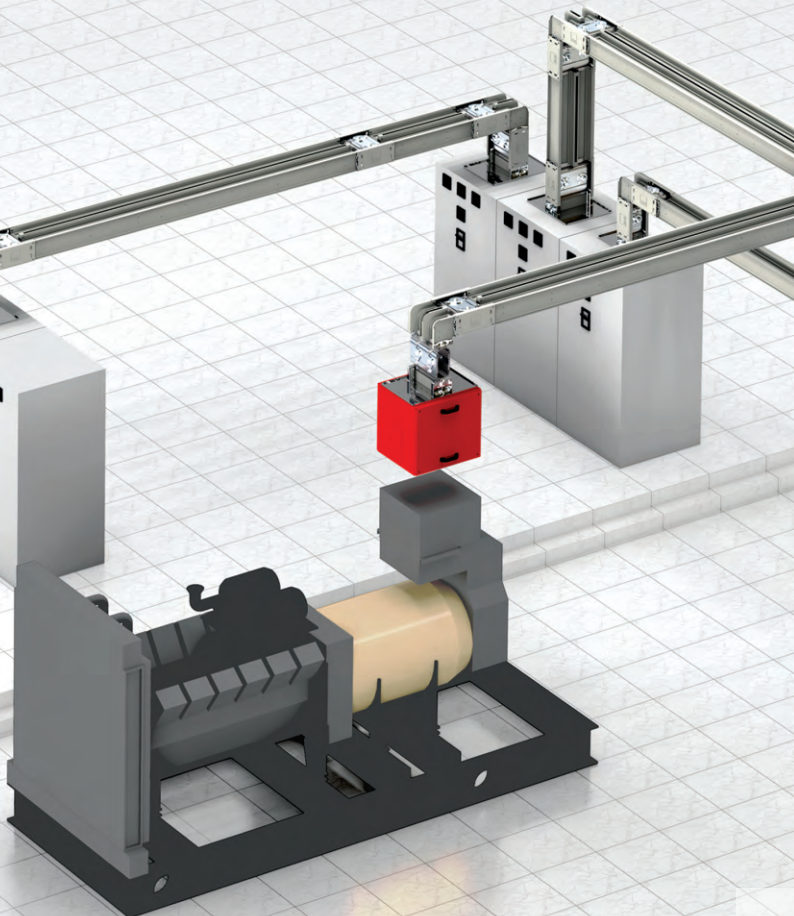



## Under Regular Surveillance

Products and Production are under regular surveillance.



## UL Listed



Coated with special paint to achieve highest durability against UV lights and corrosion.

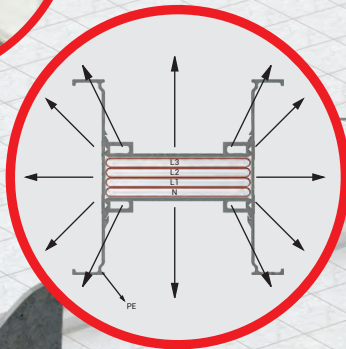

Specially designed compact structure, with no air gap, ensures perfect heat dissipation.



Extraordinary fire resistance performance.

- IEC 60331-1
- BS 8491
- BS 6387
- DIN 4102-12
- DIN 4102-9
- UL 1479



EAE designs the busbar systems for each project according to customer requirements, with focus on energy saving and efficiency.

**While designing an electrical distribution system with E-Line KX-III a few approximate details will be necessary.**

- Location, number, type and approximate ratings of loads.
- Transformer rates and short-circuit capacities, Utilization factor=A,
- System coordination with other distribution system (heat water. etc ).
- Determining the route of E-Line KX-III on layout.  
If necessary, coordination of E-Line KX-III Busbar with E-Line KO-II runs.
- Deciding on suitable hanger types.

### Utilization Factor ( $\alpha$ )

Utilization factor ( $\alpha$ ) depends on the type and number of loads. It is usually around 0.7 or lower. The utilization factor of a line that supplies electricity to motors and lighting systems is usually lower than 0.6. It is as low as 0.30 in weld shops of car factories. it can be 1 in lines where only one big load is supplied.

### Voltage Drop

For practical voltage drop calculation. necessary values. formula and easy calculation methods are given on the technical characteristics table on pages 6-9.

### Rated Current

The current is calculated using the following equation:

$$I_B = \frac{P \cdot \alpha}{\sqrt{3} \cdot U \cdot \cos \varphi}$$

- $I_B$  = Operation current (A)
- $P$  = Installed load (W)
- $\alpha$  = Utilization factor
- $U$  = Supply voltage (V)

- Busbar current rating is chosen as equal to or higher then the calculated  $I_B$  current.
- After the voltage drop calculation if the chosen current rate is not convenient. a higher rating is chosen.

### Short-Circuit

Tested short-circuit capacities are given on technical characteristics table on pages 6-9.

### Busbar Installation Plan

Our distributor's project & design departments will help you for preparing the installation plans on request.

Components List			
Item	Components	Quantity	
1	KXA-III 20507 - STD Busbar (20 x10 ft)	196 ft.	
2	KXA-III 20507 - D Downwards Elbow	2 pcs.	
3	KXA-III 20507 - R Right Elbow	1 pc.	
4	KXA-III 20507 - U Upwards Elbow	1 pc.	
5	KXA-III 20507 - L Left Elbow	1 pc.	
6	KXA-III 20507 - P11 Panel Connection	1 pc.	
7	KXA-III 20507 - S10 End Closer	1 pc.	
8	KXA-III 20507 - X95 Special Straight Length	1 pc.	
9	KXA-III 20507 - X120 Special Straight Length	1 pc.	
10	KXA-III 20507 - X122 Special Straight Length	1 pc.	
11	KXA-III 20507 - X200 Special Straight Length	1 pc.	
12	KXA-III 20507 - X174 Special Straight Length	1 pc.	
13	KXP 1650 Tap-off Box	8 pcs.	
14	KXB 2550 Tap-off Box	6 pcs.	

Company	: Demir Makine
Project	: II.OSB
Project No	: 1128
Prepared by	Name : Sumeyra SAKA
	Date : 19 / 02 / 2021
	Signature :

Project Sample



As each building's structure is different than the other for vertical applications of **E-Line KX-III** special projects has to be designed.

The details on this page briefly explain the necessary information for drawing a vertical application project.

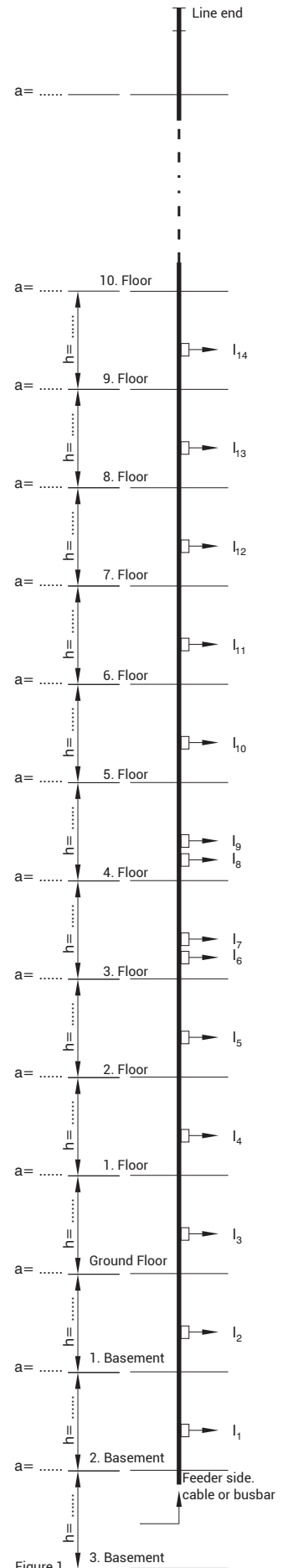
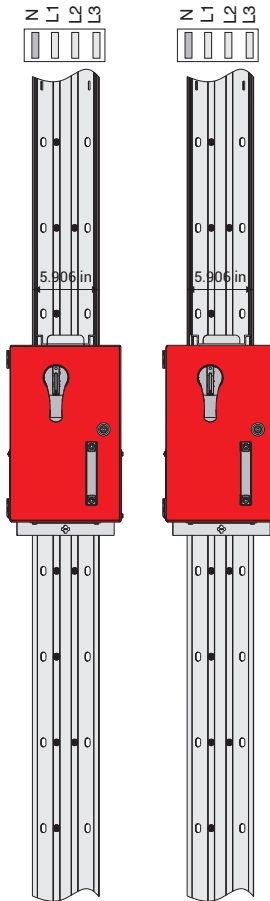
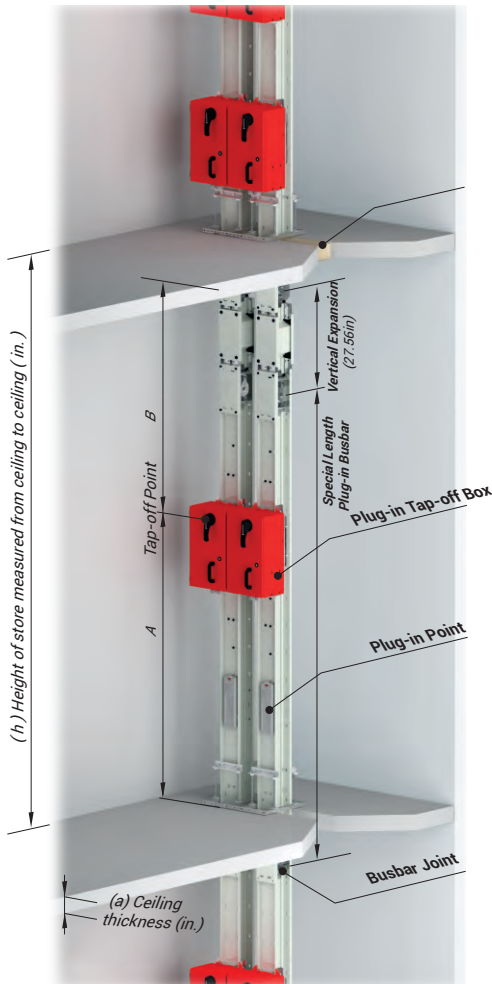

### Project Design

The details below should be sent to our Project & Design department.

- Location and dimensions of the floor penetration where busbar will be installed.
- Number, height and ceiling thickness of storeys. (a=... h=...)
- Connected load for each storey.
- Supply type of the vertical line (busbar or cable).

Please send the information to us by fax or e-mail with a sample drawing in Figure 1.

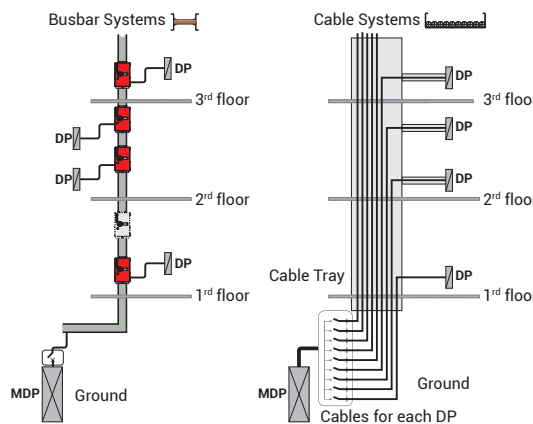

**⚠** In multipath busbars in high-rise vertical shaft applications; Due to floor heights, floor thickness and product tolerances, the window or additional point alignments on the upper floors may not be the same. In order for the Tap off boxes to be aligned and the joint point not to coincide with the floor transitions, the assembly should be continued by making measurements on each floor.

- EAE is not responsible for the potential risks that may occur in cases where the products in our catalogue are used outside of the standard phase sequences as shown in the catalogue.



# ELINEKX-III

## ►► Technical Characteristics

### Aluminium Conductor (Al)

Standards	UL 857			
Rated Operational Voltage	$U_i$	V	600	
Rated Insulation Voltage	$U_e$	Vac	600	
Rated Frequency	f	Hz	50-60	
<b>Rated Current</b>	<b>A</b>	<b>400</b>	<b>550</b>	<b>630</b>
<b>Busbar Code</b>		<b>04</b>	<b>05</b>	<b>06</b>
6 Cycle RMS Symmetrical Short Circuit Rating	kA	50	50	50
Resistance	m $\Omega$ /100ft	6.018	4.490	3.283
Reactance at 60Hz	m $\Omega$ /100ft	1.158	1.494	0.864
Impedance at 60Hz	m $\Omega$ /100ft	6.128	4.732	3.395
<b>Ground Characteristic Under Fault Condition</b>				
Resistance	m $\Omega$ /100ft	10.607	9.510	8.138
Reactance at 60Hz	m $\Omega$ /100ft	5.450	5.130	4.280
Impedance at 60Hz	m $\Omega$ /100ft	11.925	10.805	9.195
<b>SECTIONS</b>				
<b>Conductor Dimensions</b>	inch x inch	0.24x1.2	0.24x1.6	0.24x2.2
<b>L1.L2.L3.N</b>	inch <sup>2</sup>	0.28	0.37	0.51
	mm <sup>2</sup>	180	240	330
<b>PE (4 ½ Conductors)</b>	inch <sup>2</sup>	0.14	0.19	0.26
	mm <sup>2</sup>	90	120	165
<b>PE (5 Conductors)</b>	inch <sup>2</sup>	0.28	0.37	0.51
	mm <sup>2</sup>	180	240	330
<b>Aluminium Housing Section</b>	inch <sup>2</sup>	2.339	2.613	2.771
	mm <sup>2</sup>	1509	1686	1788
<b>Busbar Weight (4 Conductors)</b>	lb/ft	4.97	5.3	6.17
	kg/m	7.4	7.9	9.2
<b>Busbar Weight (5 Conductors)</b>	lb/ft	5.3	5.78	6.85
	kg/m	7.9	8.6	10.2
<b>VOLTAGE DROP FULL LOAD 60Hz per 100ft</b>				
<b>Power Factor = 0.4</b>	V/100ft	2.398	3.006	2.291
<b>Power Factor = 0.5</b>	V/100ft	2.398	3.006	2.291
<b>Power Factor = 0.6</b>	V/100ft	2.398	3.006	2.291
<b>Power Factor = 0.7</b>	V/100ft	3.491	4.010	3.181
<b>Power Factor = 0.8</b>	V/100ft	3.817	4.276	3.432
<b>Power Factor = 0.9</b>	V/100ft	4.105	4.476	3.639
<b>Power Factor = 1.0</b>	V/100ft	4.169	4.277	3.582

1- For plug-in distributed loads, divide voltage drop values by 2.

2- Actual voltage drop for different lengths and at loadings less than full rated current can be calculated using the formula:

$$VD \text{ (actual)} = VD \text{ (table)} \times (\text{actual current} / \text{rated current}) \times (\text{actual length (ft)} / 100 \text{ feet})$$

**Example:** KXA-III 1000A voltage drop at 800A .  
length 80 feet;(power factor 0.9)

$$VD \text{ (actual)} = 3.317 \times (800/1000) \times (80/100)=2.122 \text{ V}$$

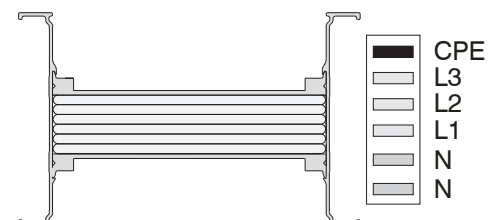
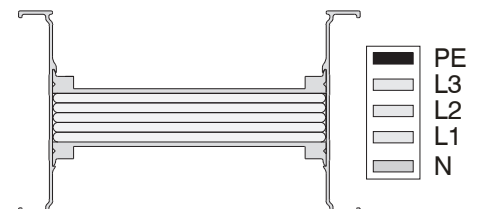

800	1000	1300	1600	2000	2500	3200	4000	5000
08	10	13	17	20	25	33	40	50
65	65	65	100	100	125	200	150	200
2.257	1.900	1.445	1.060	0.784	0.729	0.451	0.359	0.302
0.785	0.466	0.359	0.316	0.216	0.189	0.176	0.156	0.143
2.390	1.956	1.489	1.106	0.813	0.753	0.484	0.391	0.334
6.584	4.864	4.023	3.170	2.621	2.225	1.981	1.829	1.615
3.631	2.346	2.123	1.626	1.211	0.963	0.852	0.816	0.801
7.519	5.400	4.549	3.563	2.887	2.424	2.156	2.003	1.803
0.24x3.1	0.24x3.7	0.24x5.1	0.24x6.7	0.24x9.1	2x0.24x5.1	2x0.24x7.9	2x0.24x9.8	3x0.24x7.9
0.74	0.88	1.16	1.58	2.14	2.33	3.72	4.65	5.58
480	570	750	1020	1380	1500	2400	3000	3600
0.37	0.44	0.58	0.79	1.07	1.16	1.86	2.33	2.79
240	285	375	510	690	750	1200	1500	1800
0.74	0.88	1.16	1.58	2.14	2.33	3.72	4.65	5.58
480	570	750	1020	1380	1500	2400	3000	3600
2.936	3.094	3.298	3.666	4.132	6.305	7.514	8.176	11.048
1894	1996	2128	2365	2666	4068	4848	5275	7128
7.58	9.0	10.2	13.9	16.8	20.8	28.8	47.0	44.8
11.3	13.4	15.2	20.7	25.0	31.0	42.9	70	66.8
8.6	10.2	11.75	15.97	19.49	23.79	33.6	54.83	52.41
12.8	15.2	17.5	23.8	29.0	35.4	50	81.6	78.0
2.241	2.051	2.037	1.972	1.767	2.007	1.888	1.978	2.173
2.241	2.051	2.037	1.972	1.767	2.007	1.888	1.978	2.173
2.241	2.051	2.037	1.972	1.767	2.007	1.888	1.978	2.173
2.966	2.880	2.855	2.682	2.435	2.794	2.446	2.513	2.715
3.155	3.117	3.088	2.875	2.622	3.016	2.585	2.638	2.835
3.293	3.317	3.284	3.029	2.773	3.201	2.679	2.714	2.899
3.127	3.291	3.254	2.938	2.716	3.157	2.500	2.487	2.615

- To determine voltage drop line-to-neutral. multiply line-to-line values by 0.577.
- For 50 Hz. multiply reactance (X) by 0.83 and resistance values do not change.

**Voltage drop:**

$V_d = \text{load current} \times 1.732(R\cos\theta + X\sin\theta)$  per 100 ft. where  $\cos\theta = \text{Power Factor}$

- At voltage drop formula above. metric R and X can be used for voltage drop per meter

For metric conversion R, X, Z values (in Ohms per meters) use below formula by using table values

$R(\text{table}) \times 0.0328$

$X(\text{table}) \times 0.0328$

$Z(\text{table}) \times 0.0328$

**Example:** KXA-III 1000A resistance and reactance at 800A, length 80 inch ;

$R = 1.900 \times 0.0328 = 0.062$  mohm/ feet

$X = 0.466 \times 0.0328 = 0.015$  mohm/ feet

Impedance values are for busbar operating at 176 °F (80 °C) temperature.

# ELINEKX-III

## ►► Technical Characteristics

### Copper Conductor (Cu)

Standards	UL 857				
Rated Operational Voltage	$U_i$	V	600		
Rated Insulation Voltage	$U_e$	Vac	600		
Rated Frequency	f	Hz	50-60		
<b>Rated Current</b>	<b>A</b>	<b>630</b>	<b>800</b>	<b>1000</b>	<b>1250</b>
<b>Busbar Code</b>		<b>06</b>	<b>08</b>	<b>10</b>	<b>12</b>
6 Cycle RMS Symmetrical Short Curcuit Rating	kA	65	65	65	125
Resistance	m $\Omega$ /100ft	2.813	2.514	1.888	1.426
Reactance at 60Hz	m $\Omega$ /100ft	0.942	0.838	0.673	0.524
Impedance at 60Hz	m $\Omega$ /100ft	2.967	2.650	2.004	1.519
<b>Ground Characteristic Under Fault Condition</b>					
Resistance	m $\Omega$ /100ft	6.401	6.203	5.850	5.230
Reactance at 60Hz	m $\Omega$ /100ft	4.140	3.860	3.520	3.199
Impedance at 60Hz	m $\Omega$ /100ft	7.623	7.306	6.827	6.131
<b>SECTIONS</b>					
<b>Conductor Dimensions</b>	inchxinch	0.24x1.6	0.24x1.8	0.24x2.4	0.24x3.1
<b>L1.L2.L3.N</b>	inch <sup>2</sup>	0.37	0.42	0.56	0.74
	mm <sup>2</sup>	240	270	360	480
<b>PE (4 ½ Conductors)</b>	inch <sup>2</sup>	0.19	0.21	0.28	0.37
	mm <sup>2</sup>	120	135	180	240
<b>PE (5 Conductors)</b>	inch <sup>2</sup>	0.37	0.42	0.56	0.74
	mm <sup>2</sup>	240	270	360	480
<b>Aluminium Housing Section</b>	inch <sup>2</sup>	2.613	2.775	2.799	2.936
	mm <sup>2</sup>	1686	1790	1806	1894
<b>Busbar Weight (4 Conductors)</b>	lb/ft	9.68	10.89	13.44	16.46
	kg/m	14.4	16.2	20.0	24.5
<b>Busbar Weight (5 Conductors)</b>	lb/ft	11.29	12.7	15.72	19.62
	kg/m	16.8	18.9	23.4	29.2
<b>VOLTAGE DROP FULL LOAD 60Hz per 100ft</b>					
<b>Power Factor = 0.4</b>	V/100ft	2.163	2.450	2.369	2.267
<b>Power Factor = 0.5</b>	V/100ft	2.425	2.747	2.645	2.526
<b>Power Factor = 0.6</b>	V/100ft	2.664	3.019	2.895	2.760
<b>Power Factor = 0.7</b>	V/100ft	2.883	3.268	3.121	2.971
<b>Power Factor = 0.8</b>	V/100ft	3.072	3.484	3.315	3.151
<b>Power Factor = 0.9</b>	V/100ft	3.215	3.646	3.456	3.278
<b>Power Factor = 1.0</b>	V/100ft	3.070	3.484	3.270	3.087

1- For plug-in distributed loads. divide voltage drop values by 2.

2- Actual voltage drop for different lengths and at loadings less than full rated current can be calculated using the formula:

$$VD \text{ (actual)} = VD \text{ (table)} \times (\text{actual current} / \text{rated current}) \times (\text{actual length (ft)} / 100 \text{ feet})$$

**Example:** KXC-III 1000A voltage drop at 800A .  
length 80 feet;(power factor 0.9)

$$VD \text{ (actual)} = 3.456 \times (800/1000) \times (80/100)=2.211 \text{ V}$$

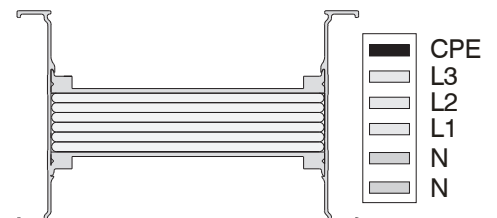
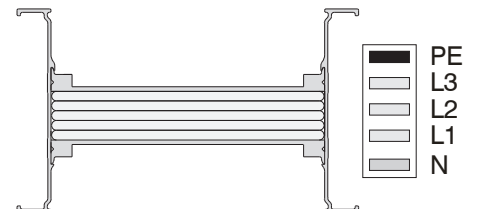



1350	1600	2000	2000	2500	3200	4000	5000	6000
14	16	20	22	26	32	40	50	60
125	125	125	200	200	200	200	200	200
1.237	0.901	0.670	0.670	0.606	0.463	0.320	0.274	0.212
0.457	0.362	0.295	0.295	0.237	0.186	0.146	0.116	0.103
1.319	0.971	0.732	0.732	0.651	0.499	0.352	0.298	0.236
4.860	3.620	2.840	2.134	1.958	1.712	1.423	1.310	1.250
3.010	2.650	2.160	1.402	1.206	1.105	0.860	0.648	0.579
5.717	4.486	3.568	2.553	2.300	2.038	1.663	1.462	1.377
0.24x3.7	0.24x5.1	0.24x6.7	2x0.24x3.1	2x0.24x3.7	2x0.24x5.1	2x0.24x7.1	3x0.24x4.1	3x0.24x7.1
0.88	1.16	1.58	1.49	1.77	2.33	3.35	3.91	5.02
570	750	1020	960	1140	1500	2160	2520	3240
0.44	0.58	0.79	0.74	0.88	1.16	1.67	1.95	2.51
285	375	510	480	570	750	1080	1260	1620
0.88	1.16	1.58	1.49	1.77	2.33	3.35	3.91	5.02
570	750	1020	960	1140	1500	2160	2520	3240
3.094	3.298	3.666	5.720	5.805	6.305	7.192	9.821	10.788
1996	2128	2365	3690	3745	4068	4640	6336	6960
18.61	24.33	31.25	33.73	36.82	47.78	65.79	76.60	98.44
27.7	36.2	46.5	50.2	54.8	71.1	97.9	114.0	146.5
22.65	29.43	37.97	39.92	44.42	57.66	80.1	93.2	119.88
33.7	43.8	56.5	59.4	66.1	85.8	119.2	138.7	178.4
2.129	1.912	1.858	1.858	1.984	1.965	1.807	1.863	1.855
2.372	2.117	2.045	2.045	2.201	2.176	1.984	2.056	2.029
2.590	2.301	2.210	2.210	2.395	2.364	2.139	2.227	2.178
2.788	2.464	2.354	2.354	2.570	2.532	2.274	2.378	2.306
2.955	2.599	2.470	2.470	2.715	2.672	2.381	2.501	2.405
3.073	2.689	2.538	2.538	2.813	2.763	2.440	2.578	2.454
2.892	2.497	2.321	2.321	2.624	2.566	2.217	2.373	2.203

### Notes

- To determine voltage drop line-to-neutral. multiply line-to-line values by 0.577.
- For 50 Hz. multiply reactance (X) by 0.83 and resistance values do not change.

#### Voltage drop:

$V_d = \text{load current} \times 1.732(R\cos\theta + X\sin\theta)$  per 100 ft. where  $\cos\theta = \text{Power Factor}$

- At voltage drop formula above. metric R and X can be used for voltage drop per meter

For metric conversion R, X, Z values (in Ohms per meters) use below formula by using table values

$R(\text{table}) \times 0.0328$

$X(\text{table}) \times 0.0328$

$Z(\text{table}) \times 0.0328$

**Example:** KXC-III 1000A resistance and reactance at 800A, length 80 inch ;

$R = 1.888 \times 0.0328 = 0.062$  mohm/ inch

$X = 0.673 \times 0.0328 = 0.022$  mohm/ inch

Impedance values are for busbar operating at 176 °F (80 °C) temperature.

## ►► Order Code System

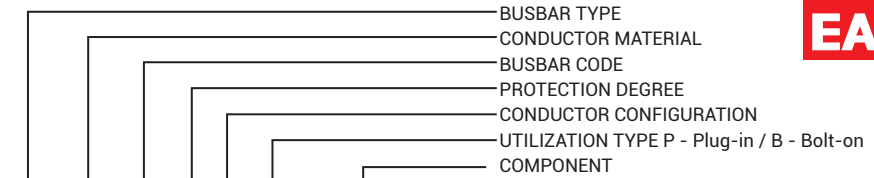

Busbar Type

Aluminium (Al) A-III  
Copper (Cu) C-III

CONDUCTOR MATERIAL

KXA-III Al Conductor		KXC-III Cu Conductor		Conductor Size	
Rated Current	Busbar Code	Rated Current	Busbar Code	(inch)	(mm)
400	04	-	-	0.24x1.18	6x30
550	05	630	06	0.24x1.57	6x40
-	-	800	08	0.24x1.77	6x45
630	06	-	-	0.24x2.17	6x55
-	-	1000	10	0.24x2.36	6x60
800	08	1250	12	0.24x3.15	6x80
1000	10	1350	14	0.24x3.74	6x95
1300	13	1600	16	0.24x4.92	6x125
1600	17	2000	20	0.24x6.69	6x170
2000	20	-	-	0.24x9.06	6x230
-	-	2000	22	2(0.24x3.15)	2(6x80)
-	-	2500	26	2(0.24x3.74)	2(6x95)
2500	25	3200	32	2(0.24x4.92)	2(6x125)
-	-	4000	40	2(0.24x7.09)	2(6x180)
3200	33	-	-	2(0.24x7.87)	2(6x200)
4000	40	-	-	2(0.24x9.84)	2(6x250)
-	-	5000	50	3(0.24x5.51)	3(6x140)
-	-	6000	60	3(0.24x7.09)	3(6x180)
5000	50	-	-	3(0.24x7.87)	3(6x200)

BUSBAR CODE

IP55 / IP65\* 5  
IP67 6

PROTECTION DEGREE

\*Please call us for IP65 orders. "Only indoor applications"

Number of Conductors	Code	Conductor Configuration									
		L1	L2	L3	N1	N2	PE	½ PE	CPE	½ CPE	PE (Housing)
4 ½ Conductors	07	✓	✓	✓	✓	✓	✓	✓	✓	✓	✓
5 Conductors	05	✓	✓	✓	✓	✓	✓	✓	✓	✓	✓
6 Conductors	06	✓	✓	✓	✓	✓	✓	✓	✓	✓	✓

*TYPE	Utilization Type
(B) Bolt-on	Energy is supplied from the joints.
(P) Plug-in	Energy is supplied from the joints and the plug-in points.

### COMPONENTS

Standard Length.....	STD
Special Length.....	X
Upwards Elbow.....	U
Downwards Elbow.....	D
Right Elbow.....	R
Left Elbow.....	L
Left Horizontal Offset.....	LH
Right Horizontal Offset.....	RH
Upwards Vertical Offset.....	UV
Downwards Vertical Offset.....	DV
Upwards Left Combined Offset.....	KUL
Upwards Right Combined Offset.....	KUR
Downwards Left Combined Offset.....	KDL
Downwards Right Combined Offset.....	KDR
Left Upwards Combined Offset.....	KLU
Right Upwards Combined Offset.....	KRU
Left Downwards Combined Offset.....	KLD
Right Downwards Combined Offset.....	KRD
End Closer.....	S
Reduction.....	RD
Left Side Feeder "T".....	TYL
Right Side Feeder "T".....	TYR
Central Feeder "T".....	TO
Horizontal Expansion.....	YDT
Vertical Expansion.....	DDT
Phase Transposition Module.....	FDM
Panel Connection.....	P10
Panel Connection.....	P11
Upwards Panel Connection.....	PU20
Upwards Panel Connection.....	PU21
Downwards Panel Connection.....	PD20
Downwards Panel Connection.....	PD21
Right Panel Connection.....	PR30
Right Panel Connection.....	PR31
Left Panel Connection.....	PL30
Left Panel Connection.....	PL31
Panel Connection.....	P40
Panel Connection.....	P41
Transformer Connection.....	TR11
Upwards Transformer Connection.....	TU21
Downwards Transformer Connection.....	TD21
Transformer Connection.....	TR31
Transformer Connection.....	TR41
Right Transformer Connection.....	TR51
Left Transformer Connection.....	TL51
Transformer Connection.....	TR61
Transformer Connection.....	TR71
Feeder Box.....	B10
Feeder Box.....	B11
Central Feeder Box.....	BO
Flexible.....	F

### Bolt-on Standard Straight Length Busbar -STD



**Sample Order:**  
**KXA-III 25507-FB-STD**  
 2500 A, Aluminium, Feeder,  
 IP 55, 4 1/2 conductors  
 Length = 10 ft / 3048mm

**Applications:**  
 • As feeder or sub-feeder line

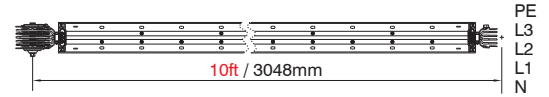

### Plug-in Standard Straight Length Busbar -STD



**Sample Order:**  
**KXC-III 12507-SP-STD**  
 1250 A, Copper, S-Plug.  
 IP 55, 4 1/2 conductors

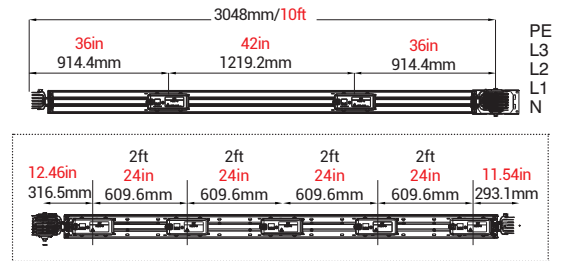

**Note:**  
 There are two plug-in tapoff points on a 10 ft standard lengths. The plug-in tapoff points are both sides of the busbar. Should you require additional plug-in tap off point please contact EAE .

### Special Straight Length -X

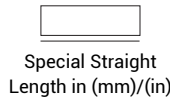

**Sample Order:**  
**KXC-III 25507-FB-X-1470**  
 2500 A, Copper, Feeder,  
 IP 55, 4 1/2 conductors. Special  
 Length = **57.87in / 1470 mm**

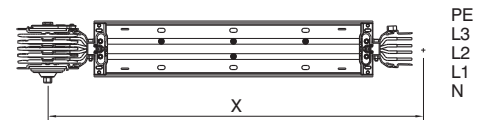

**Note:**  
 Feeder Minimum Length = **13.78in / 350mm**  
 Plug-in Minimum Length = **39.37in / 1000mm**

### Plug-in Straight Length -X



**Sample Order:**  
**KXC-III 25507-SB-X-1470**  
 2500 A, Copper, S-Plug.  
 IP 55, 4 1/2 conductors. Special  
 Length = **57.87in / 1470 mm**

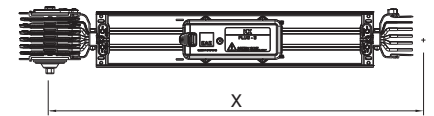

Table For Outer Dimension of Busbars

Conductors	Rated Current (A)	Busbar Dimensions (A)																		
		400	550	630	800	1000	1250	1350	1600	2000	2500	3200	4000	5000	6000	5000	6000	5000		
KXA-III Al	Busbar Code	04	05	06	08	10	12	14	16	20	22	26	32	40	50	60	732	732		
	(inch)	3.25	3.58	3.78	4.17	4.37	5.16	5.75	6.93	8.70	11.06	9.92	11.10	13.46	17.80	19.37	23.31	21.73	26.46	28.82
KXC-III Cu	Busbar Code	-	06	08	-	10	12	14	16	20	-	22	26	32	40	-	-	50	60	-
	(mm)	82.5	91	96	106	111	131	146	176	221	281	252	282	342	452	492	592	552	672	732

**Important Notice for the Tap-off box use;**

- KXA-III 400A, 550A, 630A, KXC-III 630A and 800A busbar range may have plug-in windows at one side only. It is highly recommended to consider these points in your project designs.



## ►► Elbows

### Upwards Elbow

-U

Sample Order:

**KXC-III 32507-B-U**  
3300 A, Copper, Bolton,  
IP 55, 4 1/2 conductors

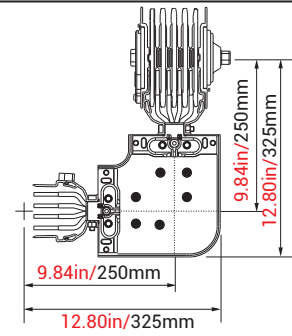

### Downwards Elbow

-D

Sample Order:

**KXC-III 32507-B-D**  
3300 A, Copper, Bolton,  
IP 55, 4 1/2 conductors

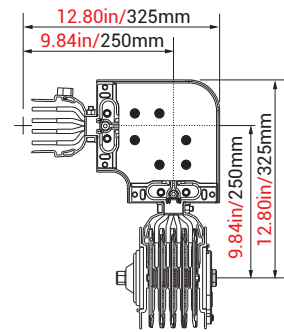
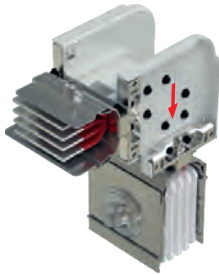

### Left Elbow

-L

Sample Order:

**KXC-III 20507-B-L**  
2000 A, Copper, Bolt-on,  
IP 55, 4 1/2 conductors

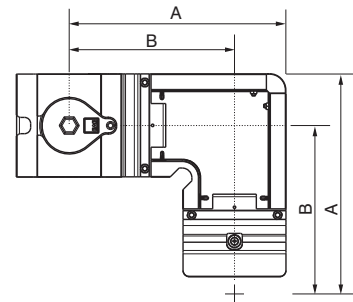
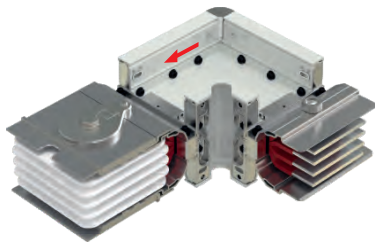

### Right Elbow

-R

Sample Order:

**KXA-III 20507-B-R**  
2000 A, Aluminium, Bolt-on,  
IP 55, 4 1/2 conductors

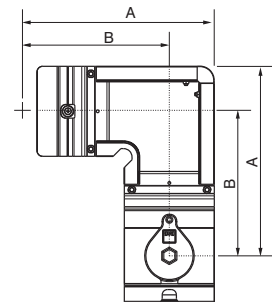
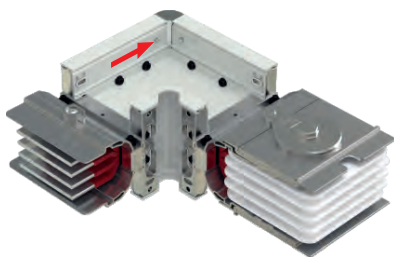

- Special left or right elbows between 90° and 180° can be manufactured upon request.
- The dimensions given above are minimum values.
- Please call us for non-standard components.

KXA-III Al Conductors	Rated Current (A)	400	550	-	630	-	800	1000	1300	1600	2000	-	-	2500	-	3200	4000	-	-	5000
	Busbar Code	04	05	-	06	-	80	10	13	17	20	-	-	25	-	33	40	-	-	50
KXC-III Cu Conductors	Rated Current (A)	-	630	800	-	1000	1250	1350	1600	2000	-	2000	2500	3200	4000	-	-	5000	6000	-
	Busbar Code	-	06	08	-	10	12	14	16	20	-	22	26	32	40	-	-	50	60	-
A	(inch)	10.12	10.51	10.71	11.10	11.30	12.08	12.68	13.86	15.63	17.99	16.81	17.99	20.35	24.69	26.26	30.20	28.62	33.35	35.71
	(mm)	257	267	272	282	287	307	322	352	397	457	427	457	517	627	667	767	727	847	907
B	(inch)	8.54	8.74	8.82	9.02	9.13	9.49	9.80	10.39	11.26	12.44	11.85	12.44	13.62	15.79	16.57	18.54	17.76	20.12	21.30
	(mm)	217	222	224	229	232	241	249	264	286	316	301	316	346	401	421	471	451	511	541

### Left Horizontal Offset

-LH

Sample Order:

**KXC-III 32507-B-LH**  
3300 A, Copper, Bolt-on,  
IP 55, 4 1/2 conductors

Note:  
X=min: **11.02in/280mm** .  
max: \*Please see table.  
Used if two horizontal elbows  
can not fit.

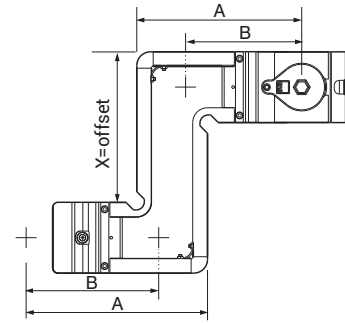
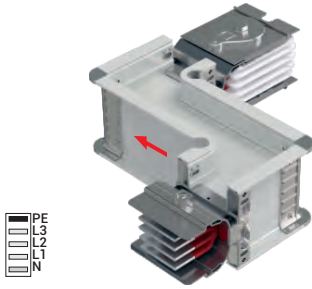

### Right Horizontal Offset

-RH

Sample Order:

**KXC-III 32507-B-RH**  
3300 A, Copper, Bolt-on,  
IP 55, 4 1/2 conductors

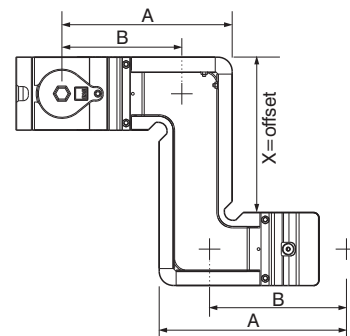
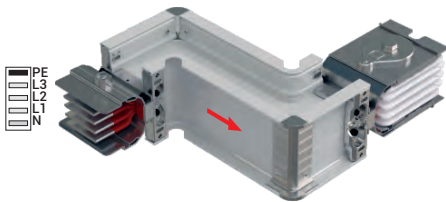

### Upwards Vertical Offset

-UV

Sample Order:

**KXA-III 20505-B-UV**  
2000 A, Aluminium, Bolt-on,  
IP 55, 5 conductors

Note:  
(\* )Offset=min: **9.84in/250mm**  
max: **19.29in/490mm**

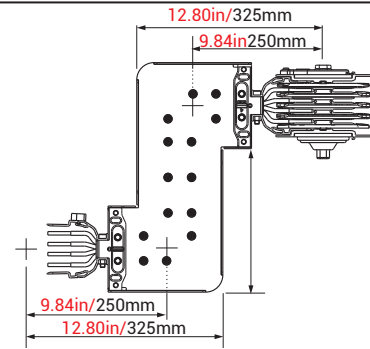
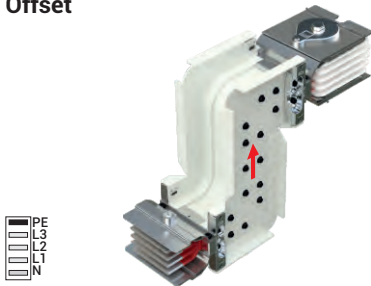

### Downwards Vertical Offset

-DV

Sample Order:

**KXA-III 20505-B-DV**  
2000 A, Aluminium, Bolt-on,  
IP 55, 5 conductors

Note:  
(\* )Offset=min: **9.84in/250mm**  
max: **19.29in/490mm**

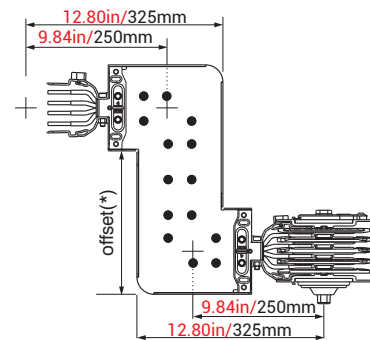
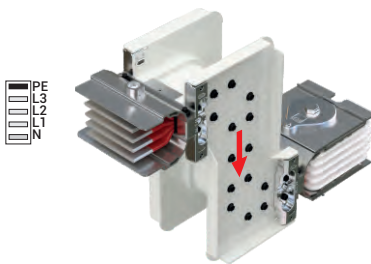

- Special left or right elbows between 90° and 180° can be manufactured upon request.
- The dimensions given above are minimum values.
- Please call us for non-standard components.

KXA-III Al Conductors	Rated Current (A)	400	550	-	630	-	800	1000	1300	1600	2000	-	-	2500	-	3200	4000	-	-	5000
	Busbar Code	04	05	-	06	-	80	10	13	17	20	-	-	25	-	33	40	-	-	50
KXC-III Cu Conductors	Rated Current (A)	-	630	800	-	1000	1250	1350	1600	2000	-	2000	2500	3200	4000	-	-	5000	6000	-
	Busbar Code	-	06	08	-	10	12	14	16	20	-	22	26	32	40	-	-	50	60	-
A	(inch)	10.12	10.51	10.71	11.10	11.30	12.08	12.68	13.86	15.63	17.99	16.81	17.99	20.35	24.69	26.26	30.20	28.62	33.35	35.71
	(mm)	257	267	272	282	287	307	322	352	397	457	427	457	517	627	667	767	727	847	907
B	(inch)	8.54	8.74	8.82	9.02	9.13	9.49	9.80	10.39	11.26	12.44	11.85	12.44	13.62	15.79	16.57	18.54	17.76	20.12	21.30
	(mm)	217	222	224	229	232	241	249	264	286	316	301	316	346	401	421	471	451	511	541
Offset <sub>max</sub>	(inch)	17.00	17.40	17.60	17.99	18.19	18.98	19.57	20.75	22.52	24.88	23.70	24.88	27.24	31.57	33.15	37.48	41.42	46.14	48.50
	(mm)	432	442	447	457	462	482	497	527	572	632	602	632	692	802	842	952	1052	1172	1232

**Upwards Left  
Combined Offset**

**-K U L**

Sample Order:

**KXC-III 32507-B-KUL**  
3300 A, Copper, Bolton,  
IP 55, 4 1/2 conductors

Note:  
Offset= min. **11.81in/300mm**

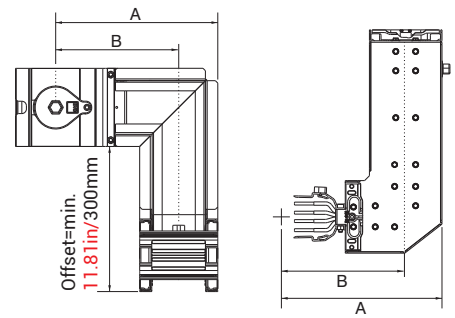

**Upwards Right  
Combined Offset**

**-K U R**

Sample Order:

**KXA-III 33507-B-KUR**  
3200 A, Aluminium, Bolton,  
IP 55, 4 1/2 conductors

Note:  
Offset= min. **11.81in/300mm**

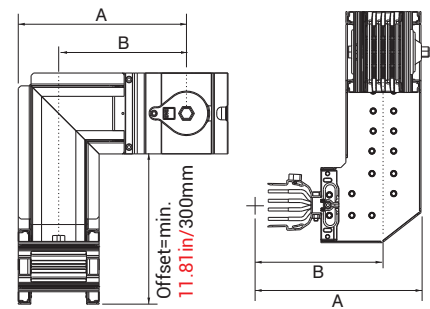

**Downwards Left  
Combined Offset**

**-K D L**

Sample Order:

**KXC-III 32507-B-KDL**  
3300 A, Copper, Bolton,  
IP 55, 4 1/2 conductors

Note:  
Offset= min. **11.81in/300mm**

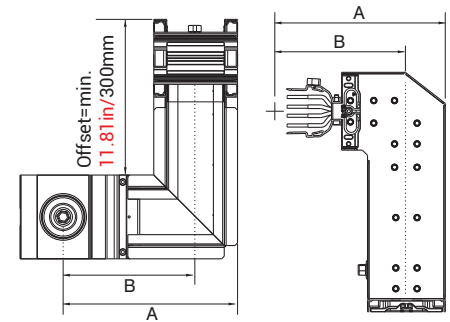
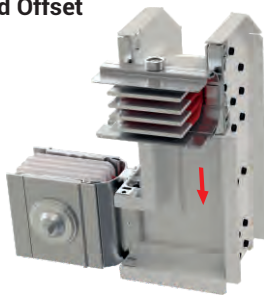

**Downwards Right  
Combined Offset**

**-K D R**

Sample Order:

**KXA-III 33507-B-KDR**  
3200 A, Aluminium, Bolt-on,  
IP 55, 4 1/2 conductors

Note:  
Offset= min. **11.81in/300mm**

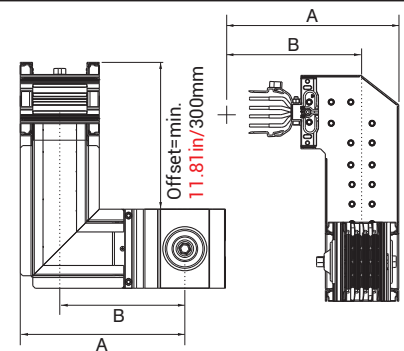
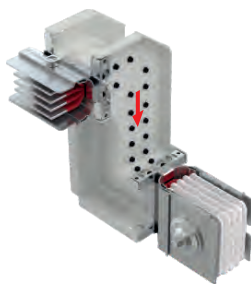

- Special left or right elbows between 90° and 180° can be manufactured upon request.
- The dimensions given above are minimum values.

KXA-III Al Conductors	Rated Current (A)	400	550	-	630	-	800	1000	1300	1600	2000	-	-	2500	-	3200	4000	-	-	5000
	Busbar Code	04	05	-	06	-	80	10	13	17	20	-	-	25	-	33	40	-	-	50
KXC-III Cu Conductors	Rated Current (A)	-	630	800	-	1000	1250	1350	1600	2000	-	2000	2500	3200	4000	-	-	5000	6000	-
	Busbar Code	-	06	08	-	10	12	14	16	20	-	22	26	32	40	-	-	50	60	-
A	(inch)	10.12	10.51	10.71	11.10	11.30	12.08	12.68	13.86	15.63	17.99	16.81	17.99	20.35	24.69	26.26	30.20	28.62	33.35	35.71
	(mm)	257	267	272	282	287	307	322	352	397	457	427	457	517	627	667	767	727	847	907
B	(inch)	8.54	8.74	8.82	9.02	9.13	9.49	9.80	10.39	11.26	12.44	11.85	12.44	13.62	15.79	16.57	18.54	17.76	20.12	21.30
	(mm)	217	222	224	229	232	241	249	264	286	316	301	316	346	401	421	471	451	511	541
Offset <sub>max</sub>	(inch)	17.00	17.40	17.60	17.99	18.19	18.98	19.57	20.75	22.52	24.88	23.70	24.88	27.24	31.57	33.15	37.48	41.42	46.14	48.50
	(mm)	432	442	447	457	462	482	497	527	572	632	602	632	692	802	842	952	1052	1172	1232



### Left Upwards Combined Offset

-K L U

Sample Order:

**KXA-III 33507-B-KLU**  
3200 A, Aluminium, Bolton,  
IP 55, 4 1/2 conductors

Note:  
Offset=min. **11.81in/300mm**

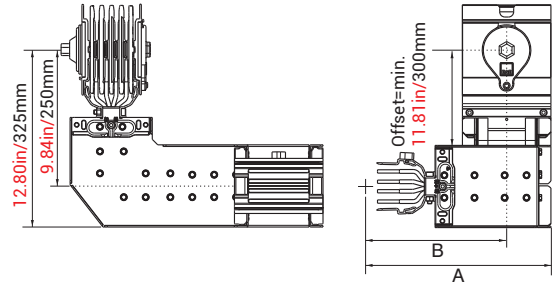

### Right Upwards Combined Offset

-K R U

Sample Order:

**KXC-III 32505-B-KRU**  
3300 A, Aluminium, Bolton,  
IP 55, 5 conductors

Note:  
Offset=min. **11.81in/300mm**

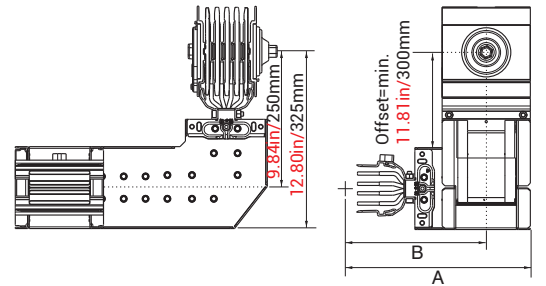
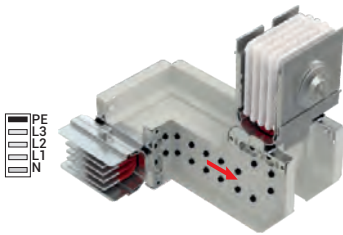

### Left Downwards Combined Offset

-K L D

Sample Order:

**KXA-III 33505-B-KLD**  
3200 A, Aluminium, Bolt-on,  
IP 55, 5 conductors

Note:  
Offset=min. **11.81in/300mm**

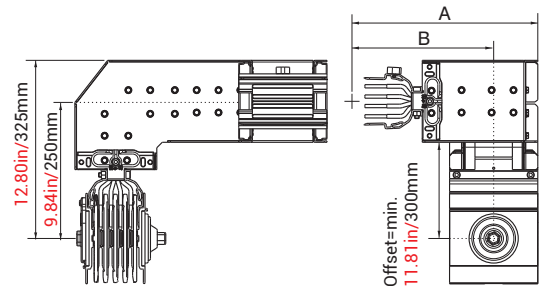
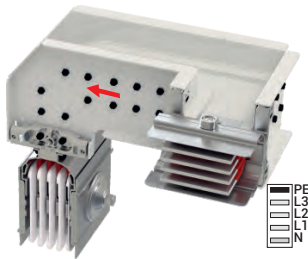

### Right Downwards Combined Offset

-K R D

Sample Order:

**KXC-III 32507-B-KRD**  
3300 A, Copper, Bolt-on,  
IP 55, 4 1/2 conductors

Note:  
Offset=min. **11.81in/300mm**

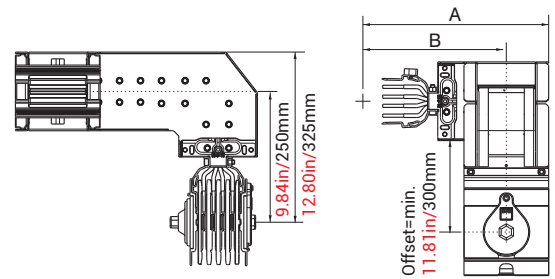
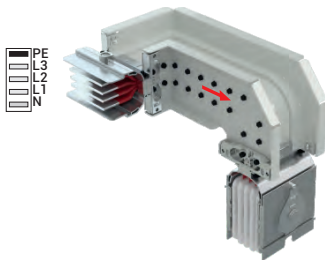

- Special left or right elbows between 90° and 180° can be manufactured upon request.
- The dimensions given above are minimum values.

KXA-III Al Conductors	Rated Current (A)	400	550	-	630	-	800	1000	1300	1600	2000	-	-	2500	-	3200	4000	-	-	5000
	Busbar Code	04	05	-	06	-	80	10	13	17	20	-	-	25	-	33	40	-	-	50
KXC-III Cu Conductors	Rated Current (A)	-	630	800	-	1000	1250	1350	1600	2000	-	2000	2500	3200	4000	-	-	5000	6000	-
	Busbar Code	-	06	08	-	10	12	14	16	20	-	22	26	32	40	-	-	50	60	-
A	(inch)	10.12	10.51	10.71	11.10	11.30	12.08	12.68	13.86	15.63	17.99	16.81	17.99	20.35	24.69	26.26	30.20	28.62	33.35	35.71
	(mm)	257	267	272	282	287	307	322	352	397	457	427	457	517	627	667	767	727	847	907
B	(inch)	8.54	8.74	8.82	9.02	9.13	9.49	9.80	10.39	11.26	12.44	11.85	12.44	13.62	15.79	16.57	18.54	17.76	20.12	21.30
	(mm)	217	222	224	229	232	241	249	264	286	316	301	316	346	401	421	471	451	511	541
Offset <sub>max</sub>	(inch)	17.00	17.40	17.60	17.99	18.19	18.98	19.57	20.75	22.52	24.88	23.70	24.88	27.24	31.57	33.15	37.48	41.42	46.14	48.50
	(mm)	432	442	447	457	462	482	497	527	572	632	602	632	692	802	842	952	1052	1172	1232

## Reduction

-RD Reduced Busbar Current

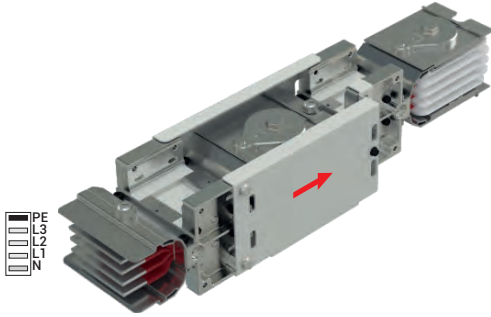

### Sample Order:

**KXA-III 20507-B-RD17**  
2000A / 1600A, Aluminium,  
Bolton, IP 55, 4 1/2 conductors

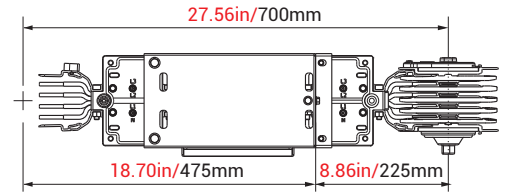

Is used to change the busbar cross section.

### Note:

Decisions and selection of reduction module and protection on lower side is under the customer's responsibility.

## Reducers Table

KXA-III Al conductors		Reduced Busbar Current										
Rated Current	400	550	630	800	1000	1300	1600	2000	2500	3200	4000	
550	✓	-	-	-	-	-	-	-	-	-	-	
630	✓	✓	-	-	-	-	-	-	-	-	-	
800	-	✓	✓	-	-	-	-	-	-	-	-	
1000	-	-	✓	✓	-	-	-	-	-	-	-	
1300	-	-	-	✓	✓	-	-	-	-	-	-	
1600	-	-	-	-	✓	✓	-	-	-	-	-	
2000	-	-	-	-	-	✓	-	-	-	-	-	
2500	-	-	-	-	-	-	✓	✓	-	-	-	
3200	-	-	-	-	-	-	-	✓	✓	-	-	
4000	-	-	-	-	-	-	-	-	✓	✓	-	
5000	-	-	-	-	-	-	-	-	-	✓	✓	

KXC-III Cu conductors		Reduced Busbar Current										
Rated Current	630	800	1000	1250	1350	1600	2000	2000	2500	3200	4000	5000
800	✓	-	-	-	-	-	-	-	-	-	-	-
1000	✓	✓	-	-	-	-	-	-	-	-	-	-
1250	-	✓	✓	-	-	-	-	-	-	-	-	-
1350	-	-	✓	✓	-	-	-	-	-	-	-	-
1600	-	-	-	✓	✓	-	-	-	-	-	-	-
2000	-	-	-	-	✓	✓	-	-	-	-	-	-
2000	-	-	-	-	-	✓	-	-	-	-	-	-
2500	-	-	-	-	-	-	✓	✓	-	-	-	-
3200	-	-	-	-	-	-	-	✓	✓	-	-	-
4000	-	-	-	-	-	-	-	-	✓	✓	-	-
5000	-	-	-	-	-	-	-	-	-	✓	✓	-
6000												

■ See table below for ratings and busbar codes.

■ The dimensions given above are minimum values.

■ Please call us for non-standard components.

### Right Side Feeder "T" -T Y R

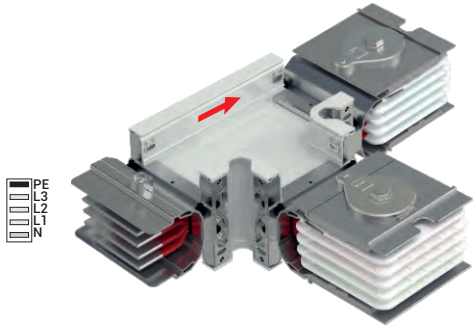

Sample Order:  
**KXC-III 25507-B-TYR**  
 2500 A, Copper, Bolt-on,  
 IP 55, 4 1/2 conductors

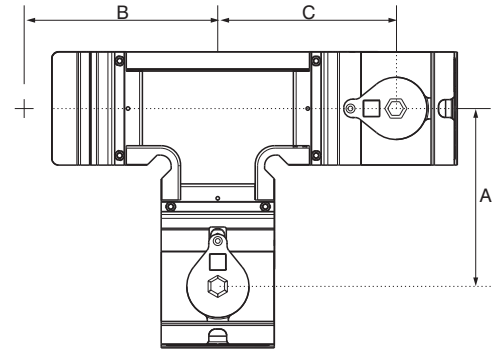

### Left Side Feeder "T" -T Y L



Sample Order:  
**KXA-III 25507-B-TYL**  
 2500 A, Aluminium, Bolt-on,  
 IP 55, 4 1/2 conductors

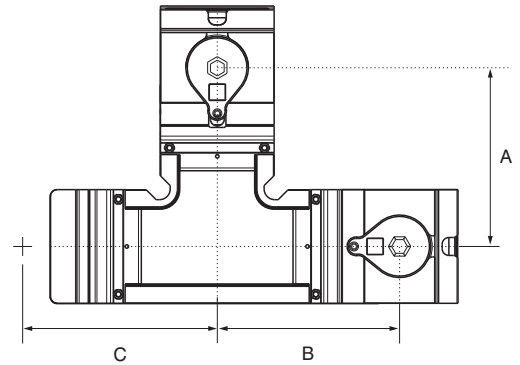

### Central Feeder "T" -T O

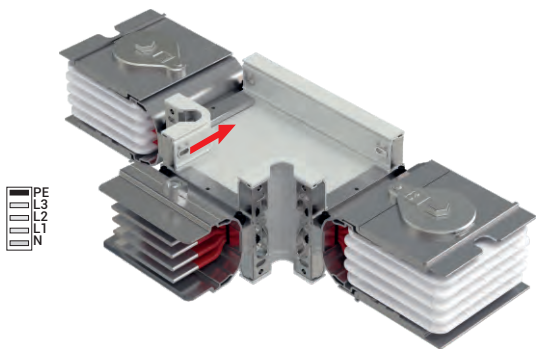

Sample Order:  
**KXC-III 32507-B-TO**  
 3300 A, Copper, Bolt-on,  
 IP 55, 4 1/2 conductors

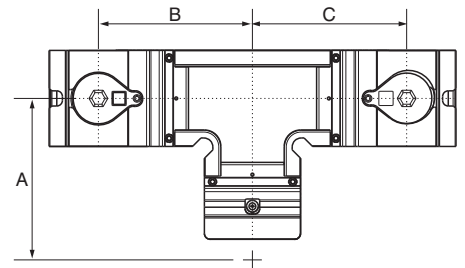

• The dimensions given above are minimum values.

• Please call us for non-standard components.

KXA-III Al Conductors	Rated Current (A)	400	550	-	630	-	800	1000	1300	1600	2000	-	-	2500	-	3200	4000	-	-	5000
	Busbar Code	04	05	-	06	-	80	10	13	17	20	-	-	25	-	33	40	-	-	50
KXC-III Cu Conductors	Rated Current (A)	-	630	800	-	1000	1250	1350	1600	2000	-	2000	2500	3200	4000	-	-	5000	6000	-
	Busbar Code	-	06	08	-	10	12	14	16	20	-	22	26	32	40	-	-	50	60	-
A	(inch)	8.50	8.70	8.82	9.02	9.13	9.49	9.80	10.39	11.26	12.44	11.85	12.44	13.62	15.79	16.57	18.54	17.76	20.12	21.30
	(mm)	216	221	224	229	232	241	249	264	286	316	301	316	346	401	421	471	451	511	541
B	(inch)	8.50	8.70	8.82	9.02	9.13	9.49	9.80	10.39	11.26	12.44	11.85	12.44	13.62	15.79	16.57	18.54	17.76	20.12	21.30
	(mm)	216	221	224	229	232	241	249	264	286	316	301	316	346	401	421	471	451	511	541
C	(inch)	8.50	8.70	8.82	9.02	9.13	18.98	9.80	10.39	11.26	12.44	11.85	12.44	13.62	15.79	16.57	18.54	17.76	20.12	21.30
	(mm)	216	221	224	229	232	241	249	264	286	316	301	316	346	401	421	471	451	511	541

## ►► Expansions

### Vertical Expansion

- B D T Sample Order:

**KXA-III 25507-B-BDT**  
2500A, Aluminium, Bolton,  
IP 55, 4 1/2 conductors

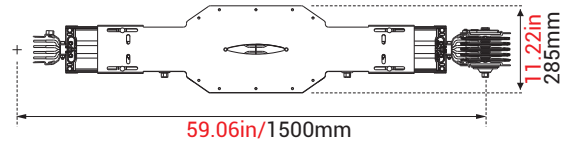
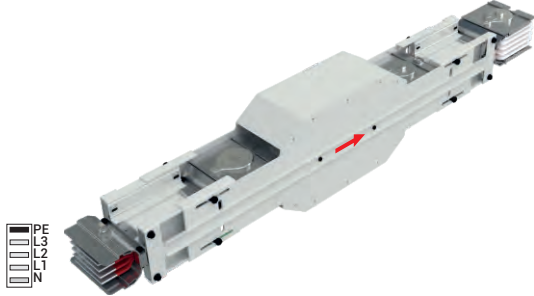

Sample Order:

**KXA-III 25507-B-BDT**  
2500A, Aluminium, Bolton,  
IP 55, 4 1/2 conductors

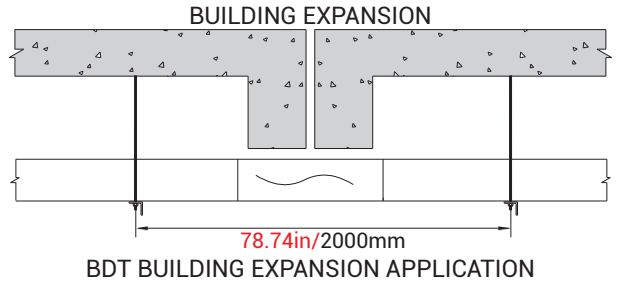

### BDT Vertical Expansion

### Vertical Expansion

-D D T Sample Order:

**KXC-III 20507-B-DDT**  
2000A, Copper, Bolton,  
IP 55, 4 1/2 conductors

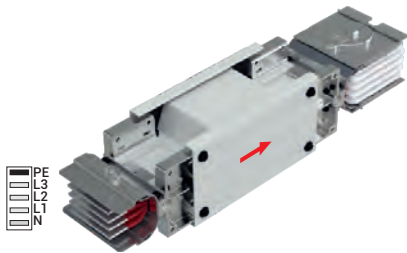

One vertical expansion unit is advised to be used at every floor between fixed support points.

Used for vertical applications in multi storey buildings.

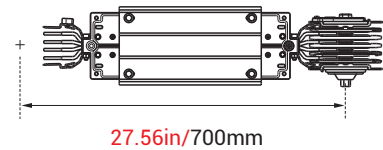

### Horizontal Expansion

-Y D T Sample Order:

**KXA-III 25507-B-YDT**  
2500A, Aluminium, Bolton,  
IP 55, 4 1/2 conductors



**Attention!**  
The total length of the module should be adjusted to **59.05in/1500mm**.after installation.  
Used at every **131ft/40m** in long horizontal straight lines and building expansion points.

**Note:**

1) Horizontal expansion joint should be utilised if busbar line is crossing to adjacent through building expansion joints.

2) This module is used on the long busbar line (>246ft/>75m) where line is ended by end closure and is not fixed on the support rigidly.

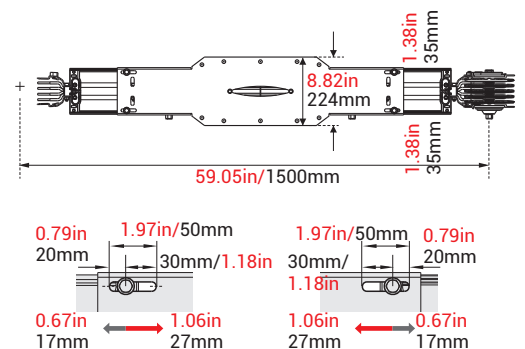

3) Horizontal expansion joint has sufficient movement span of **2.13in/54mm**

EAE requests to be consulted during design stage.

**Phase Transposition Module**

- F D M

Sample Order:

**KXA-III 25507-B-FDM**  
2500A, Aluminium, Bolton,  
IP 55, 4 1/2 conductors

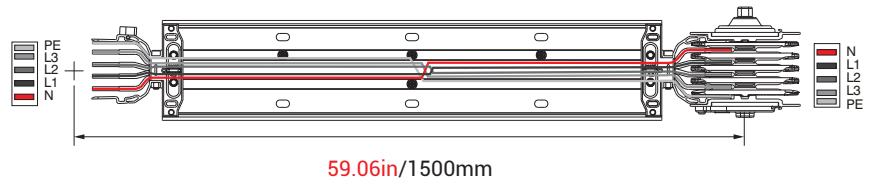

They used for transposition of phase sequence.

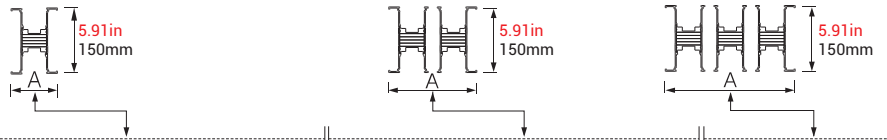

FDM Dimension Table

KXA-III Al Conductors	Rated Current (A)	400	550	-	630	-	800	1000	1300	1600	2000	-	-	2500	-	3200	4000	-	-	5000
	Busbar Code	04	05	-	06	-	80	10	13	17	20	-	-	25	-	33	40	-	-	50
KXC-III Cu Conductors	Rated Current (A)	-	630	800	-	1000	1250	1350	1600	2000	-	2000	2500	3200	4000	-	-	5000	6000	-
	Busbar Code	-	06	08	-	10	12	14	16	20	-	22	26	32	40	-	-	50	60	-
A	(inch)	3.25	3.58	3.78	4.17	4.37	5.16	5.75	6.93	8.70	11.06	9.92	11.10	13.46	17.80	19.37	23.31	21.73	26.46	28.82
	(mm)	82.5	91	96	106	111	131	146	176	221	281	252	282	342	452	492	592	552	672	732

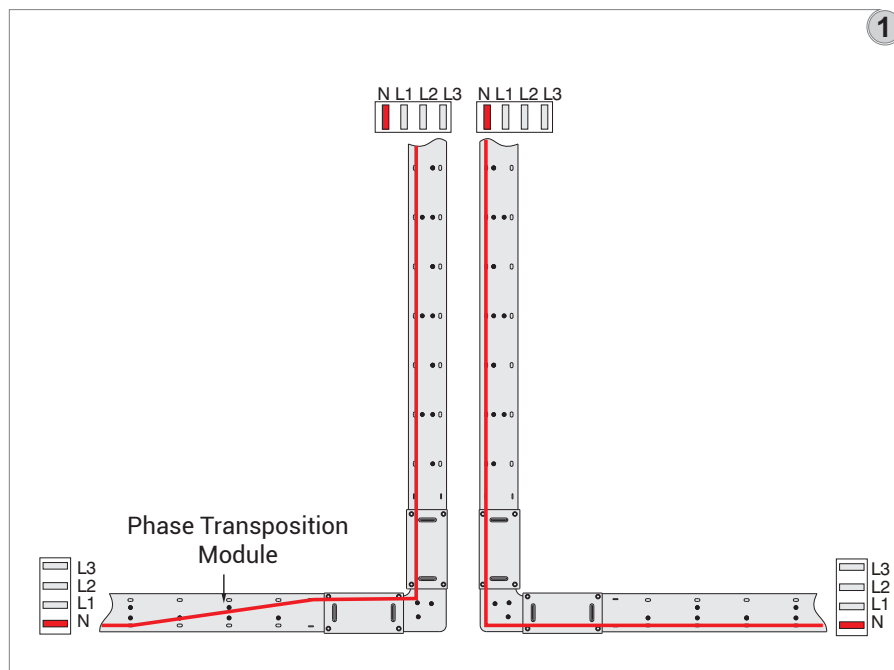

1- The neutral bar of KX busbar shall be at the bottom for horizontal busbar lines and on the left for vertical busbar lines.(Figure 1)

2- In order to maintain the neutral bar at the bottom and in the vertical busbar on the left, it is required to use the phase transposition module. (Figure 1)

■Please call us for non-standard components.

■The dimensions given above are mininum values.



**End Closer**

- S

Sample Order:

**KX-III 205A/255C-B-S**  
2000 A, Aluminium, 2500 A, Copper  
Bolt-on, IP 55, 4.5/5/6 conductors

**End Closer**  
Is used to close the end of busbar run.

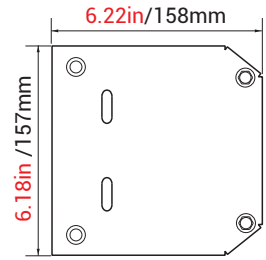
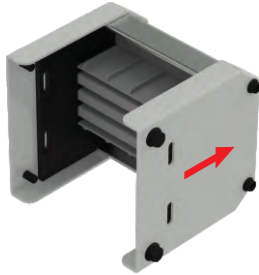

KXA-III Al Conductors	Rated Current (A)	400	550	-	630	-	800	1000	1300	1600	2000	-	-	2500	-	3200	4000
	Busbar Code	04	05	-	06	-	80	10	13	17	20	-	-	25	-	33	40
KXC-III Cu Conductors	Rated Current (A)	-	630	800	-	1000	1250	1350	1600	2000	-	2000	2500	3200	4000	-	-
	Busbar Code	-	06	08	-	10	12	14	16	20	-	22	26	32	40	-	-
Dimension	(mm)	6x30	6x40	6x45	6x55	6x60	6x80	6x95	6x125	6x170	6x230	2(6x80)	2(6x95)	2(6x125)	2(6x180)	2(6x200)	2(6x250)
Order Code		3066131	3016698	3141273	3016699	3142393	3016701	3085740	3016703	3142394	3142395	3016708	3135702	3016711	3188181	3113536	3127359

**End Closer**

- S10

Sample Order:

**KXC-III 63506-B-S10**  
6300 A, Copper, Bolt-on,  
IP 55, 6 conductors

**Note:** S10 or S11 modules should be used as end closer for the busbars with 08. 06 codes and for all IP67 products.

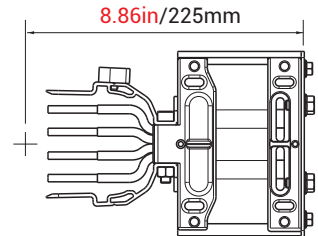
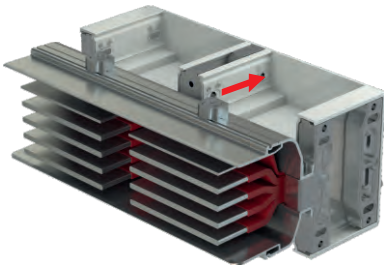

**End Closer**

- S11

Sample Order:

**KXA-III 50506-B-S11**  
5000 A, Aluminium, Bolt-on,  
IP 55, 6 conductors

**Note:** S10 or S11 modules should be used as end closer for the busbars with 08. 06 codes and for all IP67 products.

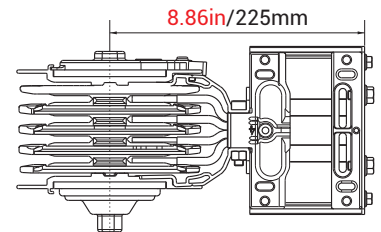
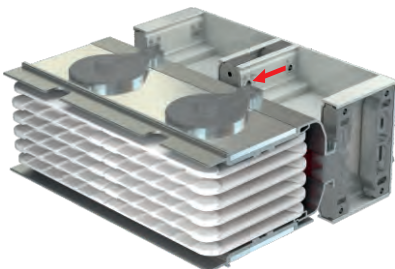

### Panel Connection Panel Feeder

- P 1 0

Sample Order:

**KXC-III 25507-B-P10**  
2500 A, Copper, Bolton,  
IP 55, 4 1/2 conductors

for Busbar Feeder

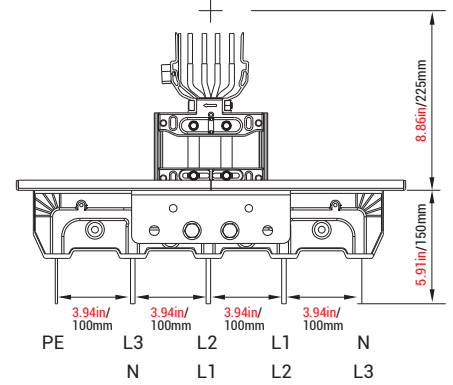
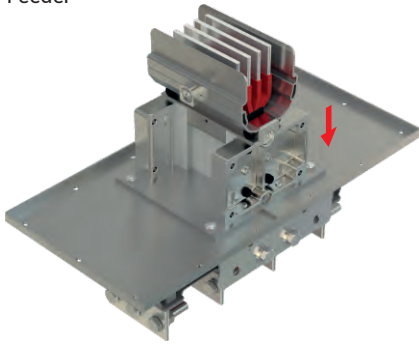

### Panel Connection Busbar Feeder

- P 1 1

Sample Order:

**KXC-III 25507-B-P11**  
2500 A, Copper, Bolton,  
IP 55, 4 1/2 conductors

for Busbar Feeder

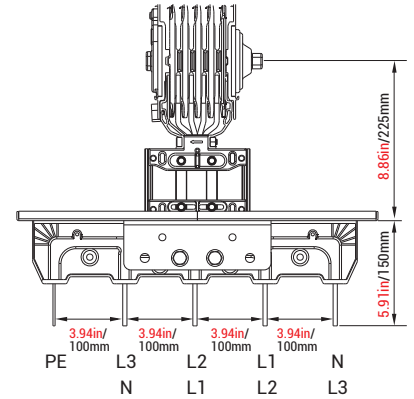
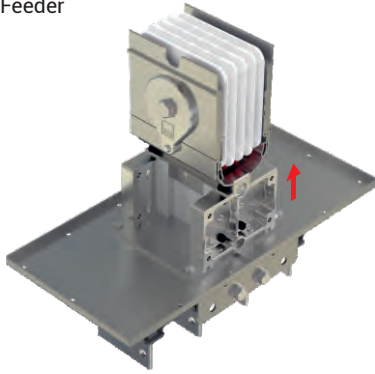

### Upwards Panel Connection Panel Feeder

- P U 2 0

Sample Order:

**KXC-III 36507-B-PU20**  
3600 A, Copper, Bolton,  
IP 55, 4 1/2 conductors

for Busbar Feeder

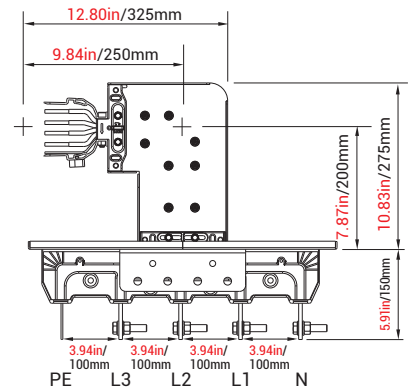
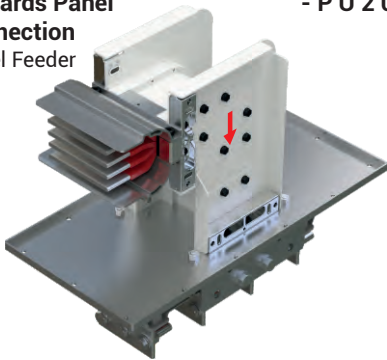

### Downwards Panel Connection Panel Feeder

- P D 2 0

Sample Order:

**KXC-III 43507-B-PD20**  
4250 A, Copper, Bolton,  
IP 55, 4 1/2 conductors

for Busbar Feeder

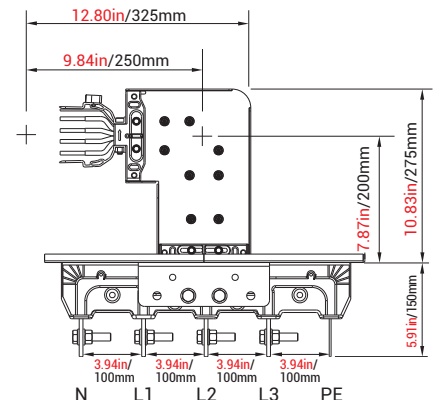
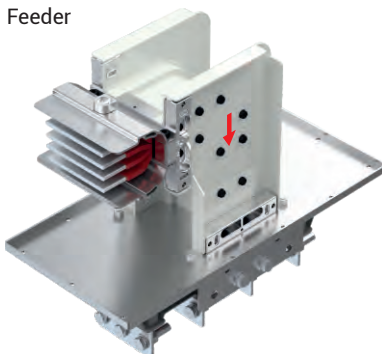

For connection dimensions please refer to tables on pages 24 and 25.

■ Distance between conductors can vary in 0.20in./±5 mm  
■ Please call us for non-standard components.

■ The dimensions given above are minimum values.

**Upwards Busbar Connection**  
Busbar Feeder

- P U 2 1

Sample Order:

**KXC-III 36507-B-PU21**  
3600 A, Copper, Bolton,  
IP 55, 4 1/2 conductors

for Busbar Feeder

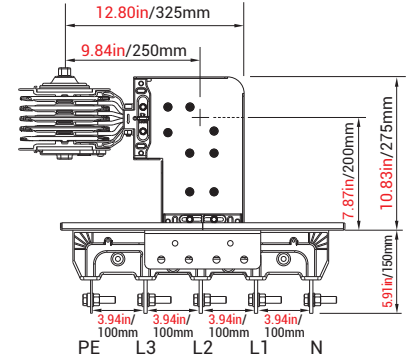
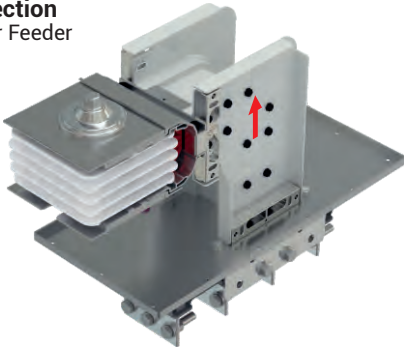

**Downwards Busbar Connection**  
Busbar Feeder

- P D 2 1

Sample Order:

**KXC 43507-B-PD21**  
4250 A, Copper, Bolton,  
IP 55, 4 1/2 conductors

for Busbar Feeder

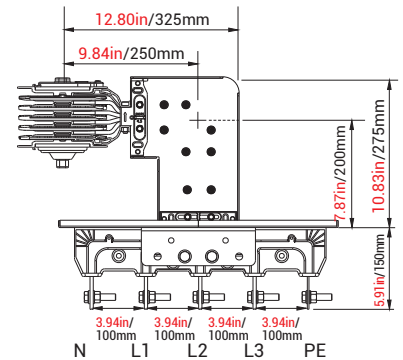
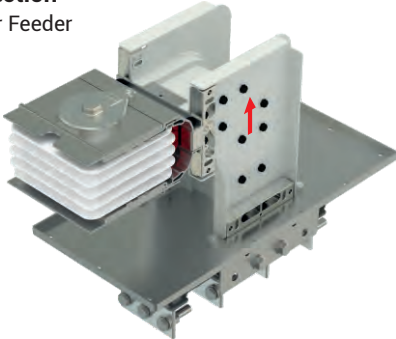

**Right Panel Connection**  
Panel Feeder

- P R 3 0

Sample Order:

**KXC 25507-B-PR30**  
3600 A, Copper, Bolton,  
IP 55, 4 1/2 conductors

for Busbar Feeder

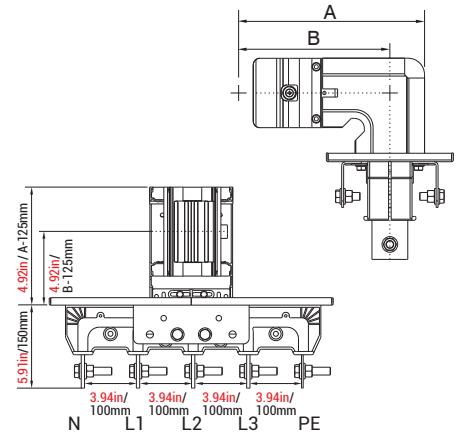
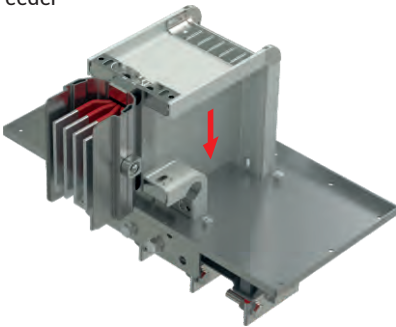

**Left Panel Connection**  
Panel Feeder

- P L 3 0

Sample Order:

**KXC 25507-B-PL30**  
2500 A, Copper, Bolton,  
IP 55, 4 1/2 conductors

for Busbar Feeder

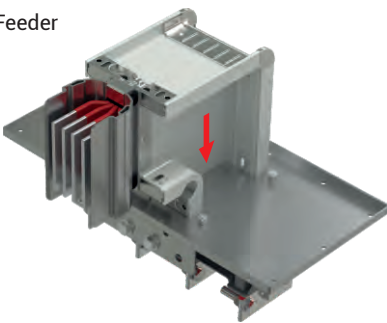

The "A" and "B" dimensions for PR30 and PL30 are the same dimensions as left and right elbows. Please refer to page 12 for the dimensions.

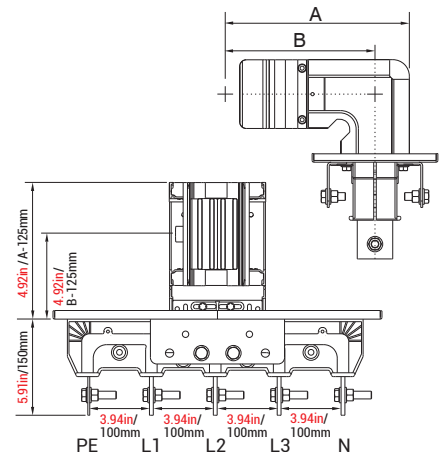

For connection dimensions please refer to tables on pages 24 and 25.

■ Distance between conductors can vary in 0.20in./±5 mm  
■ Please call us for non-standard components.

■ The dimensions given above are minimum values.

### Right Panel Connection Busbar Feeder

- P R 3 1

Sample Order:

**KXC-III 25507-B-PR31**  
2500 A, Copper, Bolton,  
IP 55, 4 1/2 conductors

for Busbar Feeder

The "A" and "B" dimensions for PR31 and PL31 are the same dimensions as left and right elbows. Please refer to page 12 for the dimensions.

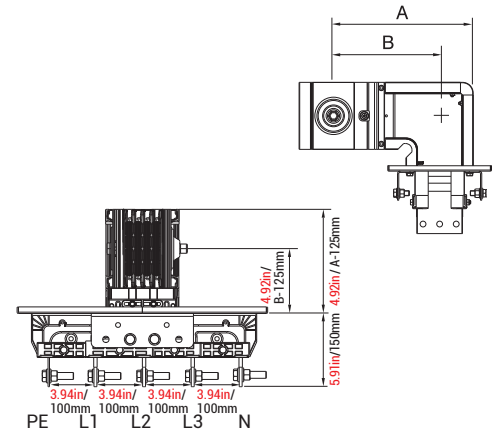
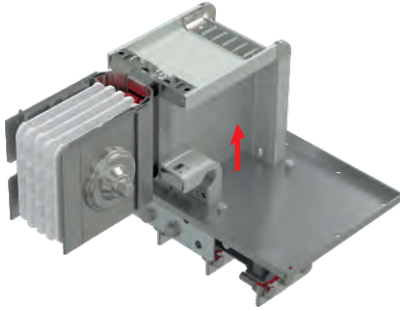

### Left Panel Connection Busbar Feeder

- P L 3 1

Sample Order:

**KXC-III 25507-B-PL31**  
2500 A, Copper, Bolton,  
IP 55, 4 1/2 conductors

for Busbar Feeder

The "A" and "B" dimensions for PR31 and PL31 are the same dimensions as left and right elbows. Please refer to page 12 for the dimensions.

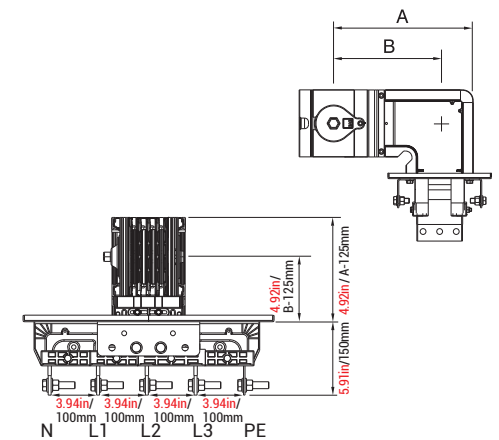
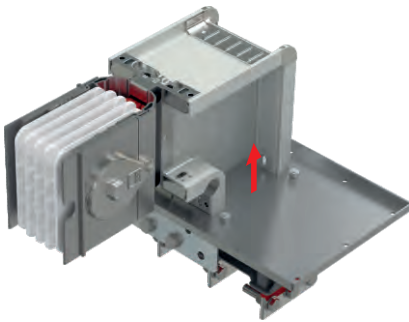

### Panel Connection Panel Feeder

- P 4 0

Sample Order:

**KXC-III 32507-B-P40**  
3300 A, Copper, Bolton,  
IP 55, 4 1/2 conductors

for Panel Feeder

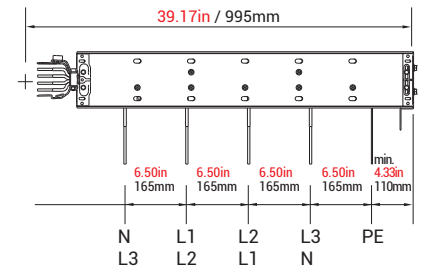

### Panel Connection Panel Feeder

- P 4 1

Sample Order:

**KXC-III 32507-B-P41**  
3300 A, Copper, Bolton,  
IP 55, 4 1/2 conductors

for Busbar Feeder

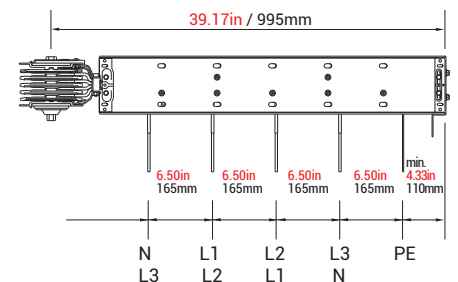
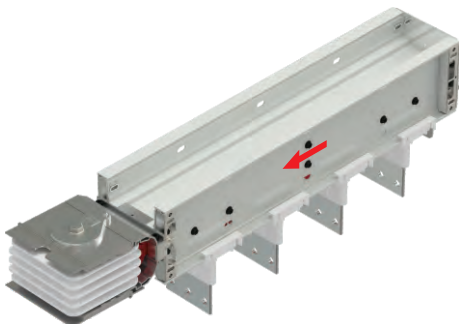

For connection dimensions please refer to tables on pages 24 and 25.

- Distance between conductors can vary in  $\pm 0.20\text{in.} / \pm 5\text{ mm}$
- The dimensions given above are minimum values.
- Please call us for non-standard components.

### Panel Connection Units For all Panel Connection Units

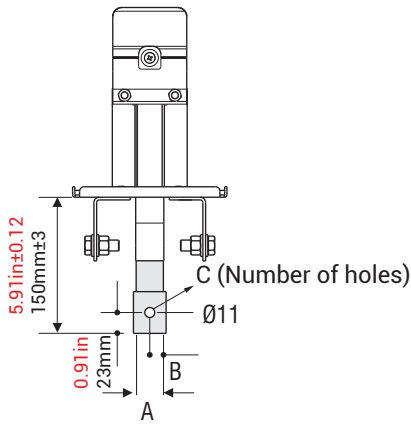

Al conductors	Cu conductors	Section		A		B		C
		(inch)	(mm)	(inch)	(mm)	(inch)	(mm)	(piece)
KXA-III 04	-	0.24x1.18	6x30	1.18	30	0.59	15	1

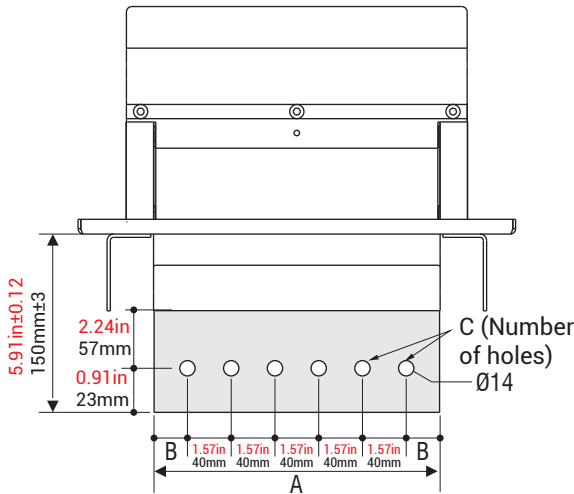

Al conductors	Cu conductors	Section		A		B		C
		(inch)	(mm)	(inch)	(mm)	(inch)	(mm)	(piece)
KXA-III 05	KXC-III 06	0.24x1.57	6x40	1.57	40	0.79	20	1
-	KXC-III 08	0.24x1.77	6x45	1.77	45	0.89	22.5	1
KXA-III 06	-	0.24x2.17	6x55	2.17	55	1.08	27.5	1
-	KXC-III 10	0.24x2.36	6x60	2.36	60	1.18	30	1
KXA-III 08	KXC-III 12	0.24x3.15	6x80	3.15	80	0.79	20	2
KXA-III 10	KXC-III 13	0.24x3.74	6x95	3.74	95	1.08	27.5	2
KXA-III 13	KXC-III 16	0.24x4.92	6x125	4.92	125	0.89	22.5	3
KXA-III 16	KXC-III 20	0.24x6.69	6x170	6.69	170	0.98	25	4
KXA-III 20	-	0.24x9.06	6x230	9.06	230	0.59	15	6
-	KXC-III 21	2(0.24x3.15)	2(6x80)	7.87	200	0.79	20	5
-	KXC-III 25	2(0.24x3.74)	2(6x95)	9.06	230	0.59	15	6
KXA-III 25	KXC-III 32	2(0.24x4.92)	2(6x125)	11.42	290	0.98	25	7
-	KXC-III 40	2(0.24x7.09)	2(6x180)	15.75	400	0.79	20	10
KXA-III 32	-	2(0.24x7.87)	2(6x200)	17.32	440	0.79	20	11
KXA-III 40	-	2(0.24x9.84)	2(6x250)	21.26	540	1.18	30	13
-	KXC-III 50	3(0.24x5.51)	3(6x140)	19.69	500	1.18	30	12
-	KXC-III 60	3(0.24x7.09)	3(6x180)	24.41	620	1.18	30	15
KXA-III 50	-	3(0.24x7.87)	3(6x200)	26.77	680	0.79	20	17

### Sample Connection

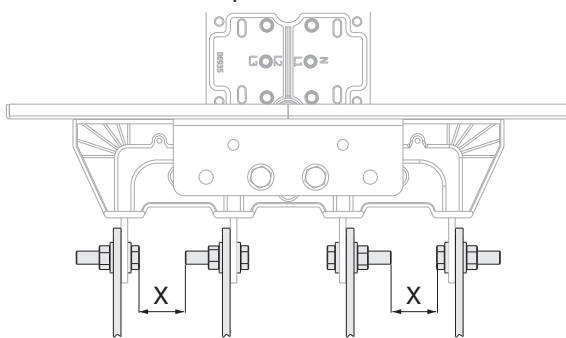

(Minimum X = 0.98in/25 mm)

■ Please call us for non-standard components. ■ Distance between conductors can vary in ±5 0.20in./±5 mm ■ The dimensions given above are minimum values.



### Flange Dimensions

Panel Connection Units are supplied with suitable flange as standard.

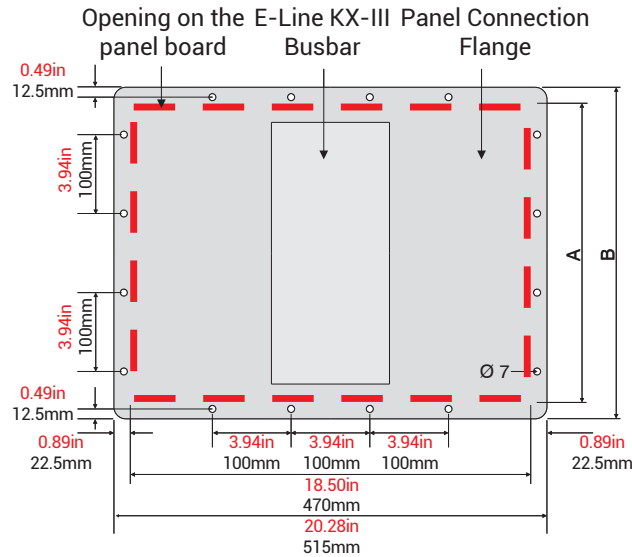
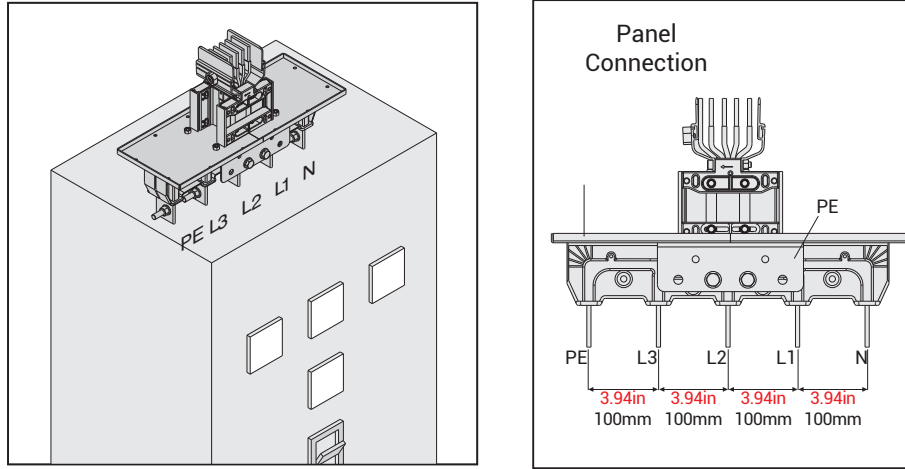

\* Bolt and nut sets are supplied together with related product as per the quantities below.

Aluminium (Al)		Copper (Cu)		Conductor Size		A		B		Number of the holes along B length	* M6 Bolt/ Nut Set(pcs)
Rated Current	Busbar Code	Rated Current	Busbar Code	(inch)	(mm)	(inch)	(mm)	(inch)	(mm)		
400	04	-	-	0.24x1.18	6x30	4.92	125	6.69	170	2	12
550	05	60	06	0.24x1.57	6x40	5.31	135	7.09	180	2	12
-	-	800	08	0.24x1.77	6x45	5.51	140	7.28	185	2	12
630	06	-	-	0.24x2.17	6x55	5.91	150	7.68	195	2	12
-	-	1000	10	0.24x2.36	6x60	6.10	155	7.87	200	2	12
800	08	1250	12	0.24x3.15	6x80	6.89	175	8.66	220	2	12
1000	10	1350	14	0.24x3.74	6x95	7.48	190	9.25	235	3	14
1300	13	1600	16	0.24x4.92	6x125	8.66	220	10.43	265	3	14
1600	17	2000	20	0.24x6.69	6x170	10.43	265	12.20	310	3	14
2000	20	-	-	0.24x9.06	6x230	12.80	325	14.57	370	4	16
-	-	2000	22	2(0.24x3.15)	2(6x80)	11.61	295	13.39	340	3	14
-	-	2500	26	2(0.24x3.74)	2(6x95)	12.80	325	14.57	370	4	16
2500	25	3200	32	2(0.24x4.92)	2(6x125)	15.16	385	16.93	430	4	16
-	-	4000	40	2(0.24x7.09)	2(6x180)	19.49	495	21.26	540	5	19
3200	33	-	-	2(0.24x7.87)	2(6x200)	21.06	535	22.83	580	6	20
4000	40	-	-	2(0.24x9.84)	2(6x250)	25.00	635	26.77	680	7	22
-	-	5000	50	3(0.24x5.51)	3(6x140)	23.43	595	25.20	640	7	22
-	-	6000	60	3(0.24x7.09)	3(6x180)	28.15	715	29.92	760	8	24
5000	50	-	-	3(0.24x7.87)	3(6x200)	30.51	775	32.28	820	8	24

### Transformer Connection

- T R 1 1

Sample Order:

**KXA-III 25507-B-TR11**  
2500 A, Aluminium, Bolton,  
IP 55, 4 1/2 conductors

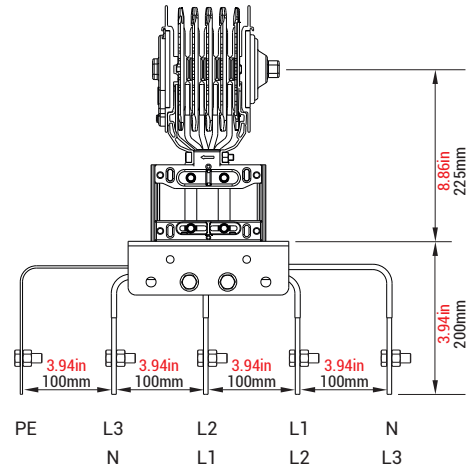
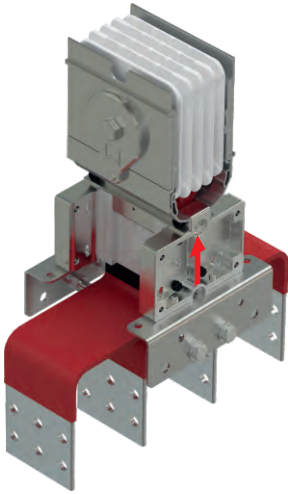

### Upwards Transformer Connection

- T U 2 1

Sample Order:

**KXC-III 25507-B-PL21**  
2500 A, Copper, Bolton,  
IP 55, 4 1/2 conductors

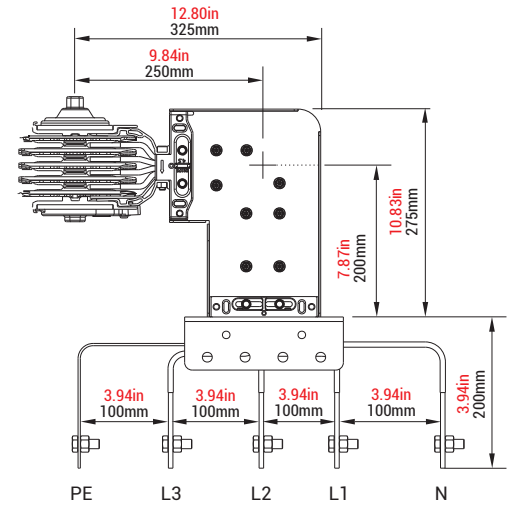
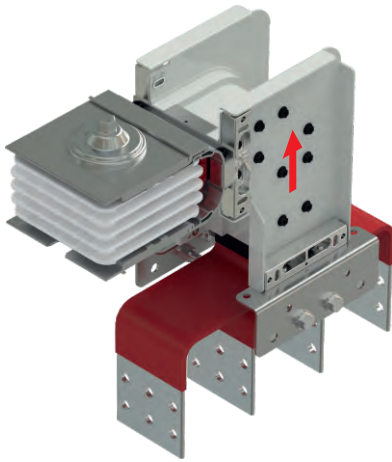

### Downwards Transformer Connection

- T D 2 1

Sample Order:

**KXA-III 25504-B-TD21**  
2500 A, Aluminium, Bolton,  
IP 55, 4 1/2 conductors

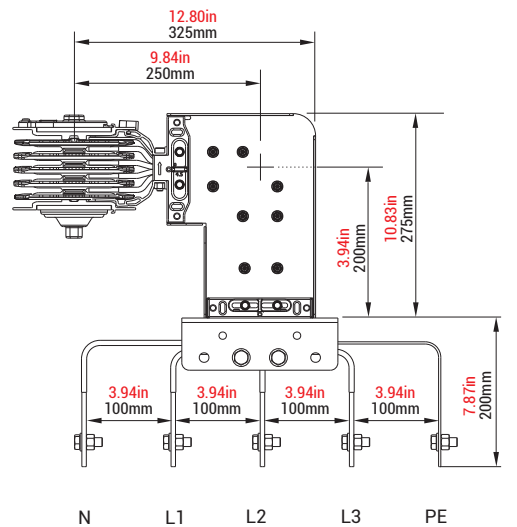
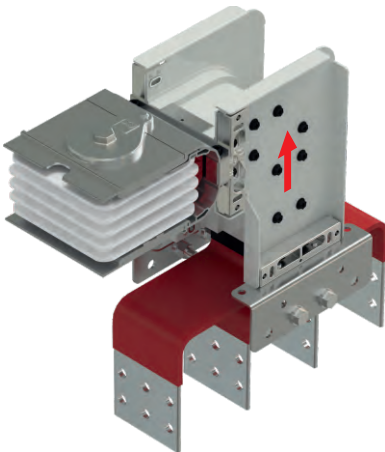

For connection dimensions please refer to tables on pages 29 and 30.

■ Distance between conductors can vary in  $\pm 5$  0.20in./ $\pm 5$  mm  
■ Please call us for non-standard components.

■ The dimensions given above are minimum values.

### Transformer Connection

- TR 3 1

Sample Order:

**KXC-III 25507-B-TR31**  
2500 A, Copper, Bolton,  
IP 55, 4 1/2 conductors

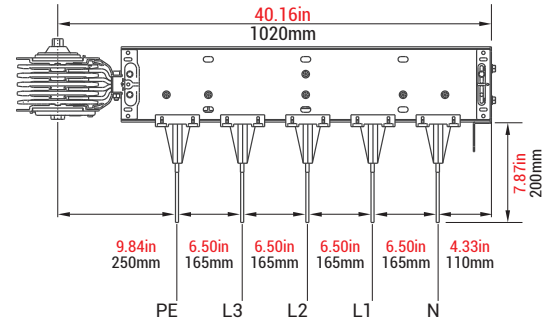
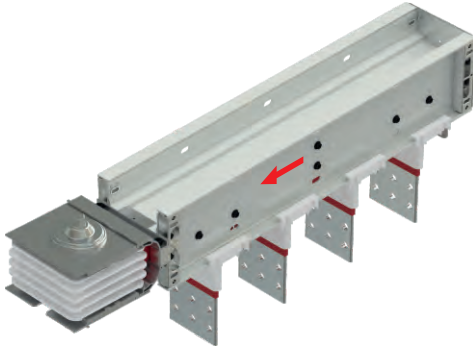

### Flexibles

- F   
L  
(in/cm)

Sample Order:

**KXA 0800-F40**  
800 A, Aluminium

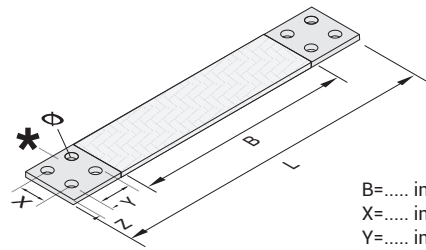

B=..... in/mm  
X=..... in/mm  
Y=..... in/mm  
Z=..... in/mm  
ø=..... in/mm

\*This side is punched according to the needs of the customer.

Flexible are used for

- Transformer - busbar.
- Panel - busbar connections.

### Right Transformer Connection

- TR 5 1

Sample Order:

**KXC-III 25507-B-TR51**  
2500 A, Copper, Bolton,  
IP 55, 4 1/2 conductors

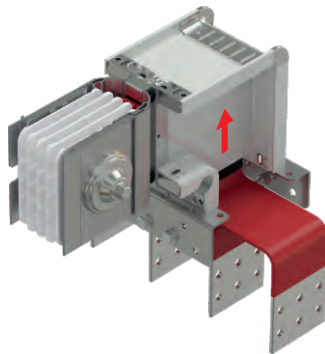

A and B dimensions of TR51 and TL51 are same as left and right elbows. Please refer to page 12 for the dimensions.

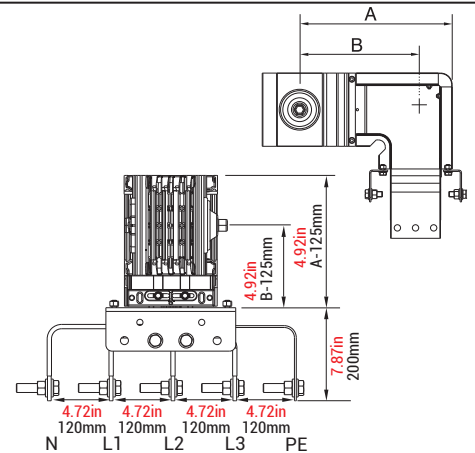

### Left Transformer Connection

- TL 5 1

Sample Order:

**KXA-III 25507-B-TL51**  
2500 A, Aluminium, Bolton,  
IP 55, 4 1/2 conductors

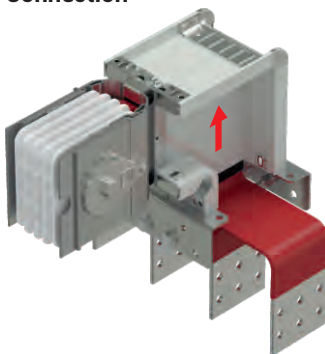

A and B dimensions of TR51 and TL51 are same as left and right elbows. Please refer to page 12 for the dimensions.

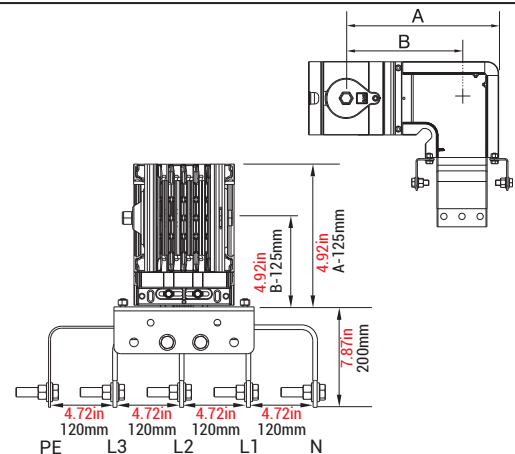

For connection dimensions please refer to tables on page 30.

- Distance between conductors can vary in  $\pm 5$  0.20in./ $\pm 5$  mm
- Please call us for non-standard components.

■ The dimensions given above are minimum values.

## ▶▶ Transformer Connections

**Transformer Connection - T R 4 1** Sample Order:  
**KXC-III 25507-B-TR41**  
 3200 A, Copper, Bolton,  
 IP 55, 4 1/2 conductors

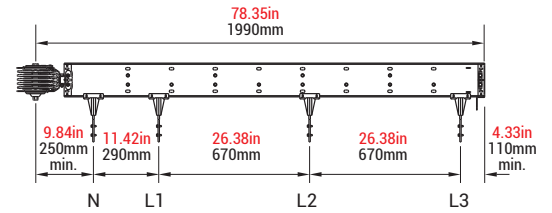

**Transformer Connection - T R 6 1** Sample Order:  
**KXC-III 36507-B-TR61**  
 3600 A, Copper, Bolton,  
 IP 55, 4 1/2 conductors

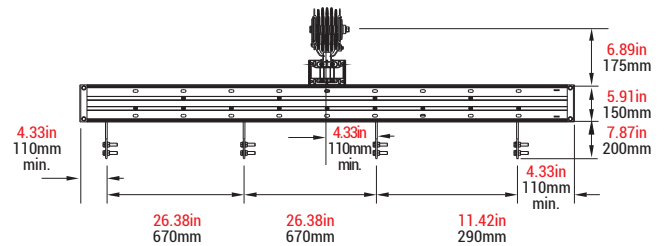
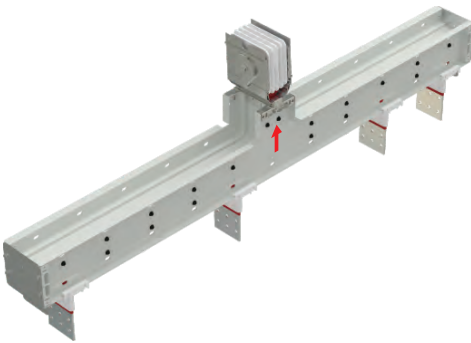

**Transformer Connection - T R 7 1** Sample Order:  
**KXC-III 40507-B-TR71**  
 4000 A, Copper, Bolt-on,  
 IP 55, 4 1/2 conductors

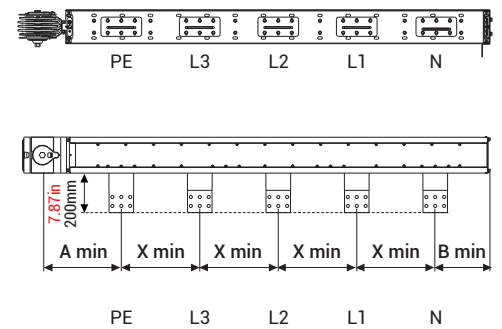
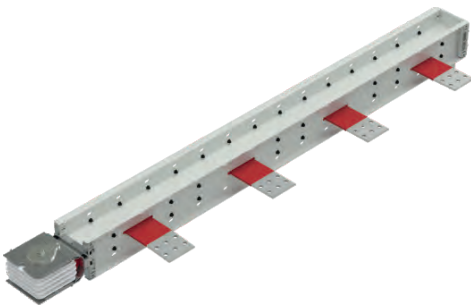

■ Distance between conductors can vary in  $\pm 0.20\text{in.}/\pm 5\text{ mm}$   
 ■ Please call us for non-standard components.

■ The dimensions given above are minimum values.

For connection dimensions please refer to tables on page 30.

KXA-III Al Conductors	Rated Current (A)	400	550	-	630	-	800	1000	1300	1600	2000	-	-	2500	-	3200	4000	-	-	5000
	Busbar Code	04	05	-	06	-	80	10	13	17	20	-	-	25	-	33	40	-	-	50
KXC-III Cu Conductors	Rated Current (A)	-	630	800	-	1000	1250	1350	1600	2000	-	2000	2500	3200	4000	-	-	5000	6000	-
	Busbar Code	-	06	08	-	10	12	14	16	20	-	22	26	32	40	-	-	50	60	-
A <sub>min</sub>	(inch)	10.12	10.51	10.71	11.10	11.30	12.08	12.68	13.86	15.63	17.99	16.81	17.99	20.35	24.69	26.26	30.20	28.62	33.35	35.71
	(mm)	257	267	272	282	287	307	322	352	397	457	427	457	517	627	667	767	727	847	907
B <sub>min</sub>	(inch)	8.54	8.74	8.82	9.02	9.13	9.49	9.80	10.39	11.26	12.44	11.85	12.44	13.62	15.79	16.57	18.54	17.76	20.12	21.30
	(mm)	217	222	224	229	232	241	249	264	286	316	301	316	346	401	421	471	451	511	541
X <sub>min</sub>	(inch)	17.00	17.40	17.60	17.99	18.19	18.98	19.57	20.75	22.52	24.88	23.70	24.88	27.24	31.57	33.15	37.48	41.42	46.14	48.50
	(mm)	432	442	447	457	462	482	497	527	572	632	602	632	692	802	842	952	1052	1172	1232

### Transformer Connection Units

#### Transformer Connection Units (TR31. TR41. TR61)

Note: No flange supplied with transformer connection units.

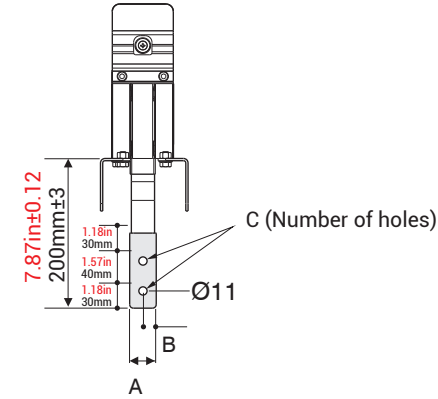

Al conductors	Cu conductors	Section		A		B		C
		(inch)	(mm)	(inch)	(mm)	(inch)	(mm)	(piece)
KXA-III 04	-	0.24x1.18	6x30	1.18	30	0.59	15	1

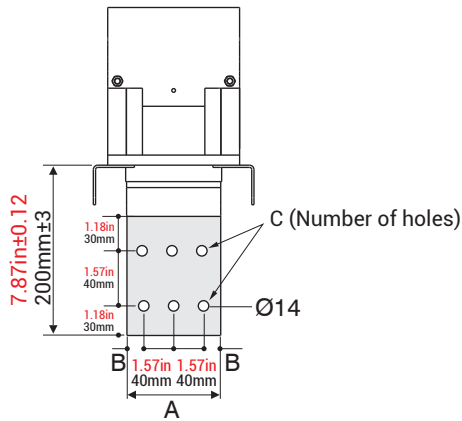

Al conductors	Cu conductors	Section		A		B		C
		(inch)	(mm)	(inch)	(mm)	(inch)	(mm)	(piece)
KXA-III 05	KXC-III 06	0.24x1.57	6x40	1.57	40	0.79	20	1+1
-	KXC-III 08	0.24x1.77	6x45	1.77	45	0.89	22.5	1+1
KXA-III 06	-	0.24x2.17	6x55	2.17	55	1.08	27.5	1+1
-	KXC-III 10	0.24x2.36	6x60	2.36	60	1.18	30	1+1
KXA-III 08	KXC-III 12	0.24x3.15	6x80	3.15	80	0.79	20	2+2
KXA-III 10	KXC-III 13	0.24x3.74	6x95	3.74	95	1.08	27.5	2+2
KXA-III 13	KXC-III 16	0.24x4.92	6x125	4.92	125	0.89	22.5	3+3
KXA-III 16	KXC-III 20	0.24x6.69	6x170	6.69	170	0.98	25	4+4
KXA-III 20	-	0.24x9.06	6x230	9.06	230	0.59	15	6+6

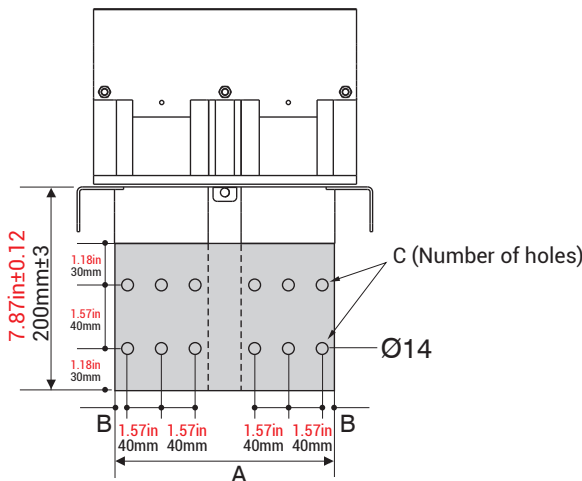

Al conductors	Cu conductors	Section		A		B		C
		(inch)	(mm)	(inch)	(mm)	(inch)	(mm)	(piece)
-	KXC-III 21	2(0.24x3.15)	2(6x80)	7.87	200	0.79	20	4+4
-	KXC-III 25	2(0.24x3.74)	2(6x95)	9.06	230	1.08	27.5	4+4
KXA-III 25	KXC-III 32	2(0.24x4.92)	2(6x125)	11.42	290	0.89	22.5	6+6
-	KXC-III 40	2(0.24x7.09)	2(6x180)	15.75	400	1.18	30	8+8
KXA-III 32	-	2(0.24x7.87)	2(6x200)	17.32	440	0.79	20	10+10
KXA-III 40	-	2(0.24x9.84)	2(6x250)	21.26	540	0.89	22.5	12+12
-	KXC-III 50	3(0.24x5.51)	3(6x140)	19.69	500	1.18	30	9+9
-	KXC-III 60	3(0.24x7.09)	3(6x180)	24.41	620	1.18	30	12+12
KXA-III 50	-	3(0.24x7.87)	3(6x200)	26.77	680	0.79	20	15+15

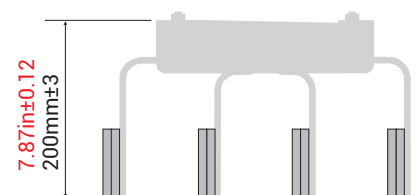

■ Please call us for non-standard components. ■ Distance between conductors can vary in ±0.20in./±5 mm ■ The dimensions given above are minimum values.



### Transformer Connection Units

#### Transformer Connection Units (TR11. TU21. TD21. TR51. TL51)

Note: No flange supplied with transformer connection units.

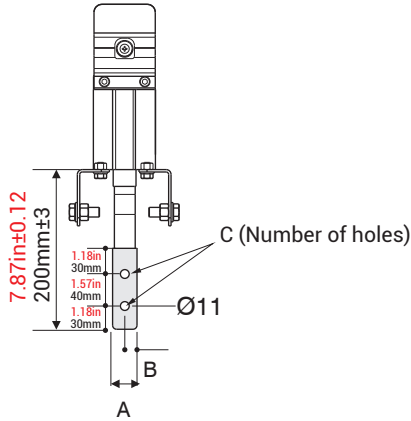

Al conductors	Cu conductors	Section		A		B		C (piece)
		(inch)	(mm)	(inch)	(mm)	(inch)	(mm)	
KXA-III 04	-	0.24x1.18	6x30	1.18	30	0.59	15	1

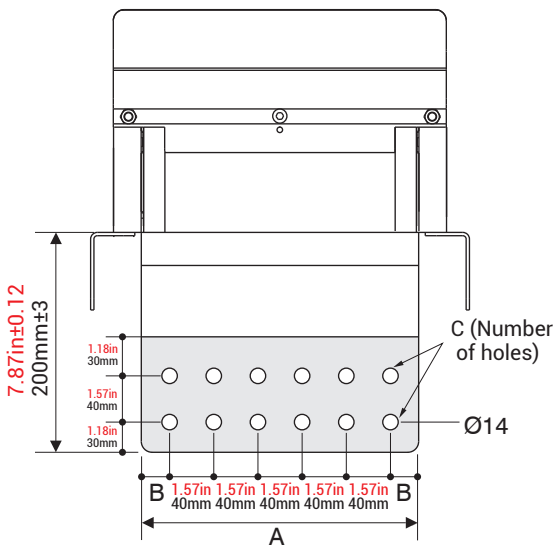

Al conductors	Cu conductors	Section		A		B		C (piece)
		(inch)	(mm)	(inch)	(mm)	(inch)	(mm)	
KXA-III 05	KXC-III 06	0.24x1.57	6x40	1.57	40	0.79	20	1+1
-	KXC-III 08	0.24x1.77	6x45	1.77	45	0.89	22.5	1+1
KXA-III 06	-	0.24x2.17	6x55	2.17	55	1.08	27.5	1+1
-	KXC-III 10	0.24x2.36	6x60	2.36	60	1.18	30	1+1
KXA-III 08	KXC-III 12	0.24x3.15	6x80	3.15	80	0.79	20	2+2
KXA-III 10	KXC-III 13	0.24x3.74	6x95	3.74	95	1.08	27.5	2+2
KXA-III 13	KXC-III 16	0.24x4.92	6x125	4.92	125	0.89	22.5	3+3
KXA-III 16	KXC-III 20	0.24x6.69	6x170	6.69	170	0.98	25	4+4
KXA-III 20	-	0.24x9.06	6x230	9.06	230	0.59	15	6+6
-	KXC-III 21	2(0.24x3.15)	2(6x80)	7.87	200	0.79	20	5+5
-	KXC-III 25	2(0.24x3.74)	2(6x95)	9.06	230	0.59	15	6+6
KXA-III 25	KXC-III 32	2(0.24x4.92)	2(6x125)	11.42	290	0.98	25	7+7
-	KXC-III 40	2(0.24x7.09)	2(6x180)	15.75	400	0.79	20	10+10
KXA-III 32	-	2(0.24x7.87)	2(6x200)	17.32	440	0.79	20	11+11
KXA-III 40	-	2(0.24x9.84)	2(6x250)	21.26	540	1.18	30	13+13
-	KXC-III 50	3(0.24x5.51)	3(6x140)	19.69	500	1.18	30	12+12
-	KXC-III 60	3(0.24x7.09)	3(6x180)	24.41	620	1.18	30	15+15
KXA-III 50	-	3(0.24x7.87)	3(6x200)	26.77	680	0.79	20	17+17

#### Sample Connection

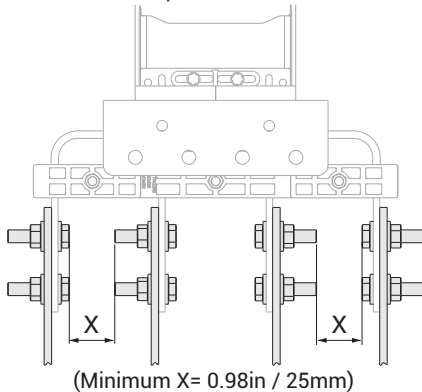

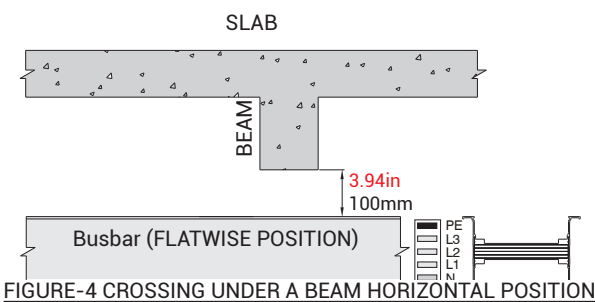
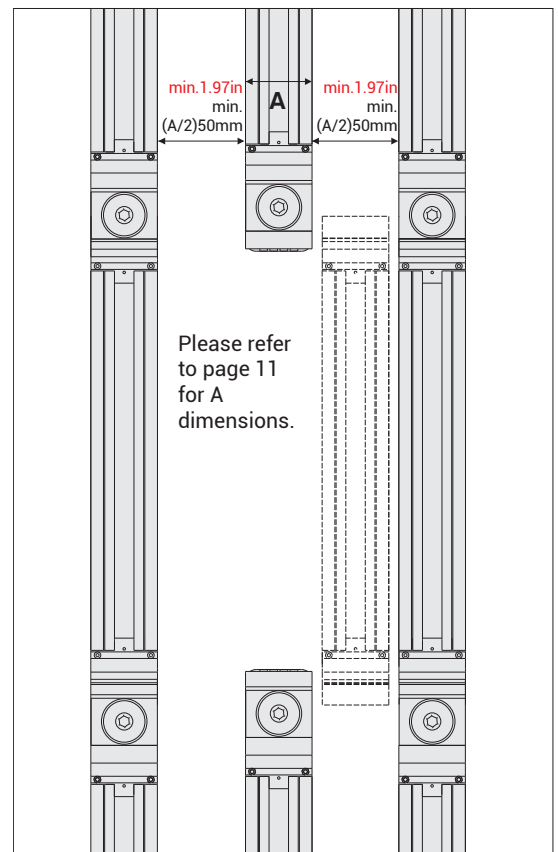
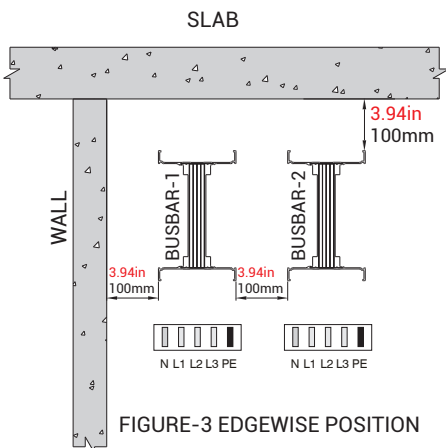
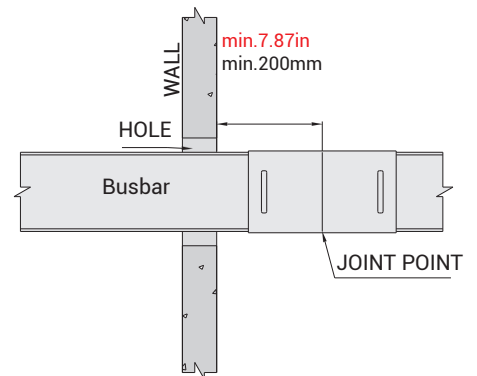
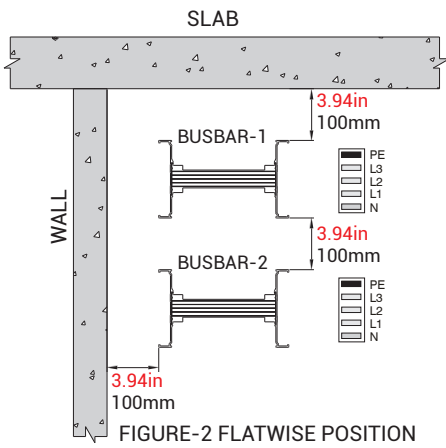
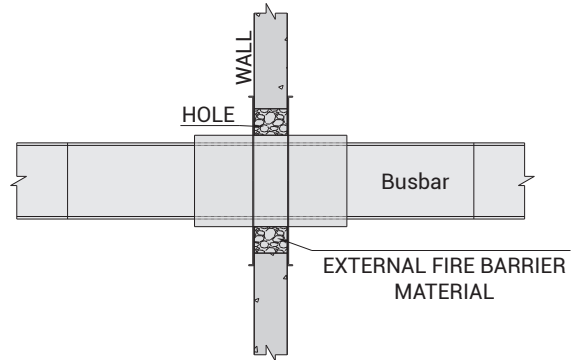
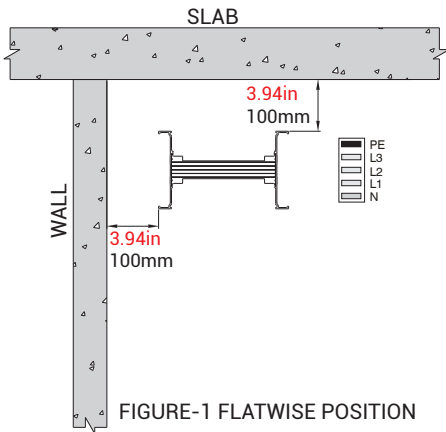

■ The dimensions given above are minimum values. ■ All measures are given in inch / mm

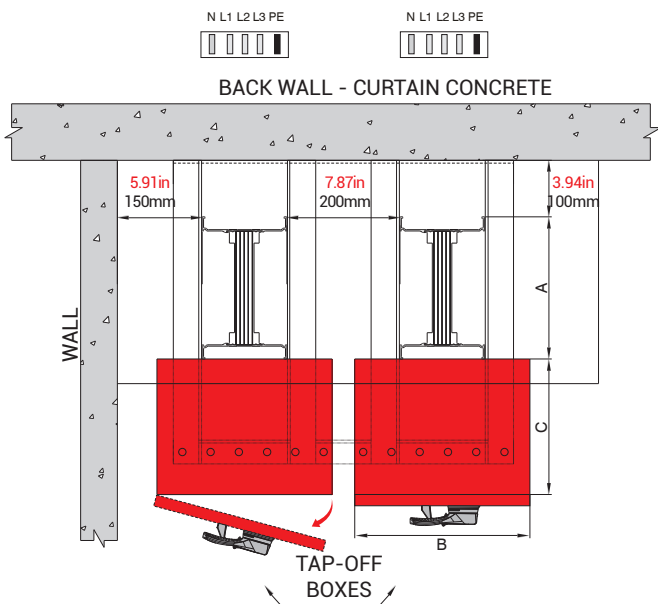
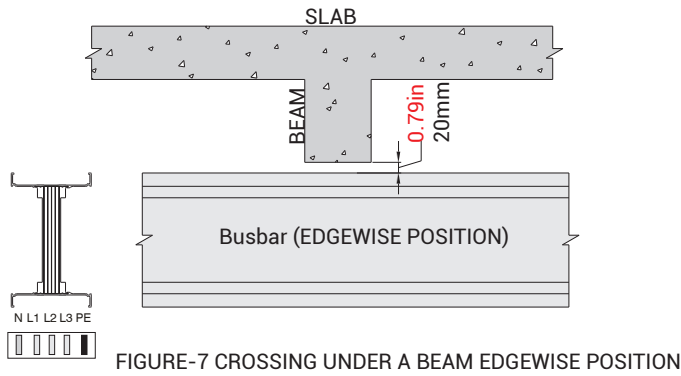

**NOTE:** In order to accommodate the busbar systems in the riser shaft;

**MDM**= Minimum Distance from the wall

**"A" dimension** = All dimensions are for standard modules.

**"C" dimension** = Please see page 31-32 and special dimension for Tap-off box "C" dimension.

**"B" dimension** = Max. opening distance for Tap-off box cover.

**Shaft Dimension** =  $MDM + A + C + B + 3.94\text{in}/100\text{mm}$  Shown as (Figure-8)

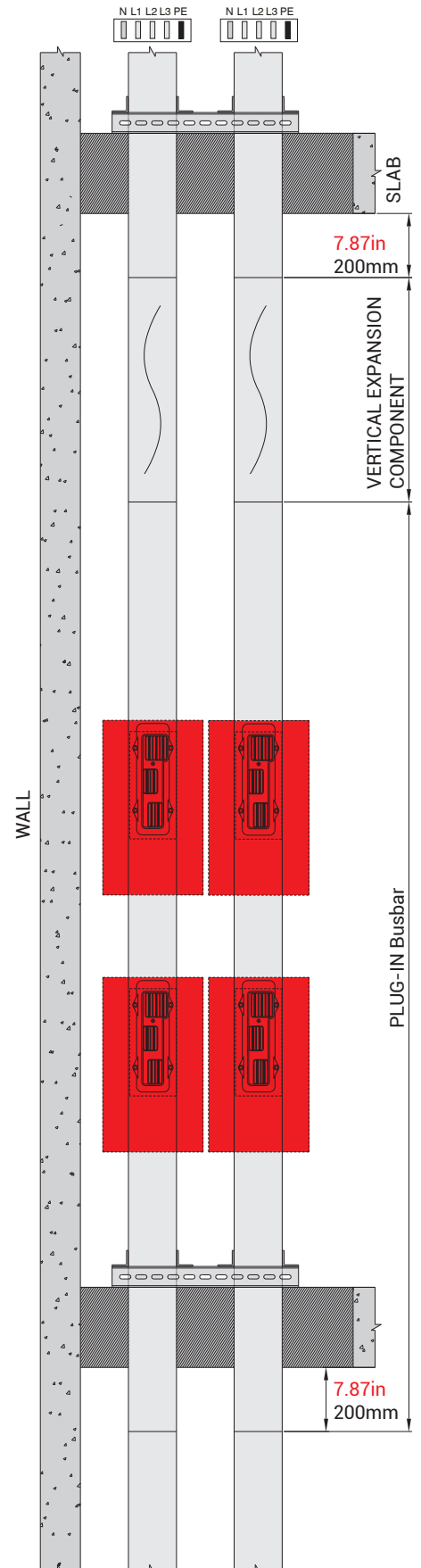

■ The dimensions given above are minimum values. ■ All measures are given in inch./mm

## Supports

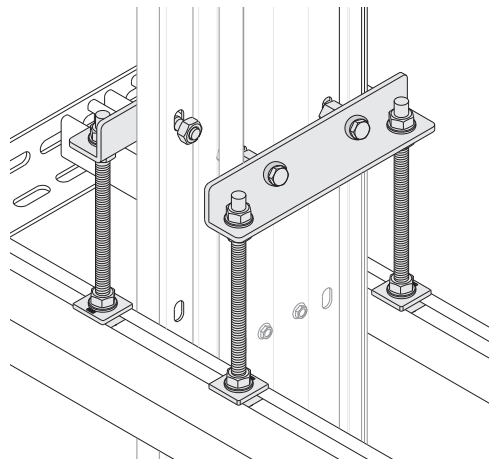
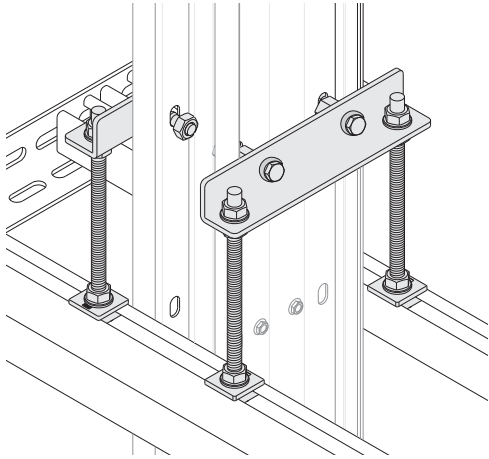

## Fixing Elements

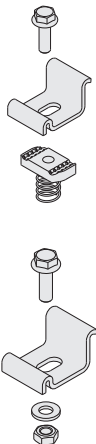

Description	Code
KX Vertical Riser Fixing Unit	3048475

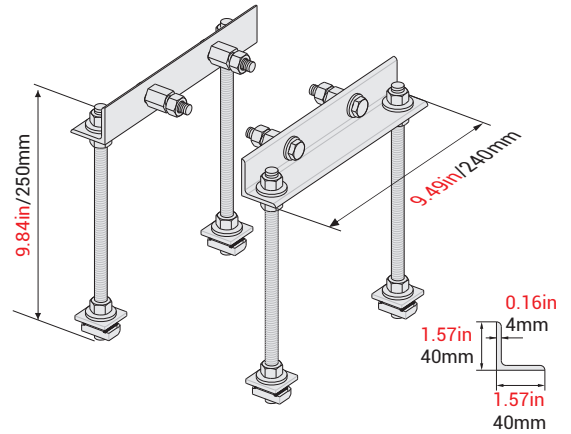

Description	Code
KX Vertical Riser Fixing Unit (Fire Barrier)	3048709

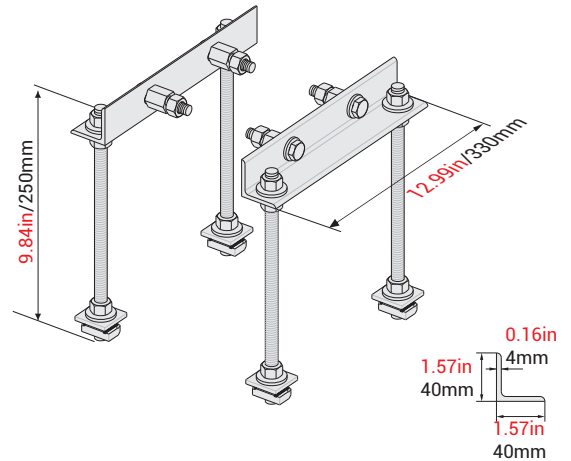

Description	Code
KX Fixing Clamp for Binrak(Unistrut) Channel	2011227

Description	Code
KX Fixing Clamp for Steel Angle Profile	2011226

■ The dimensions given above are minimum values. ■ All measures are given in inch./mm

## Supports

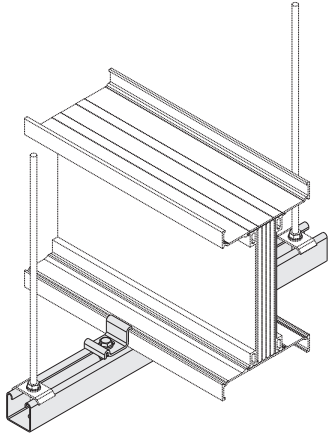

**KX - BRA HANGER SET FOR EDGEWISE APPLICATION TO BINRAK (UNISTRUT) CHANNEL**

Al Conductor		Cu Conductor		L		A		Order Code
Rated Current	Busbar Code	Rated Current	Busbar Code	(inch)	(mm)	(inch)	(mm)	
400	04	-	-	13.78	350	3.25	82.5	3025372
550	05	630	06			3.58	91	
-	-	800	08			3.78	96	
630	06	-	-			4.17	106	
-	-	1000	10			4.37	111	
800	08	1250	12			5.16	131	
1000	10	1350	14			5.75	146	
1300	13	1600	16			6.93	176	
1600	17	2000	20			8.70	221	
2000	20	-	-			11.06	281	

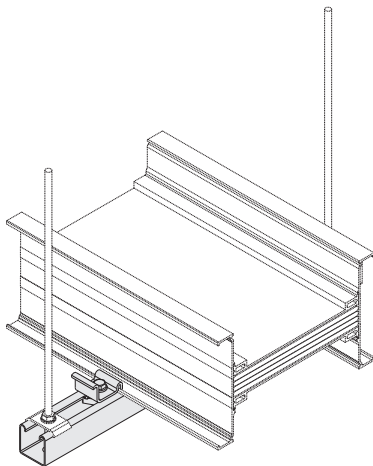
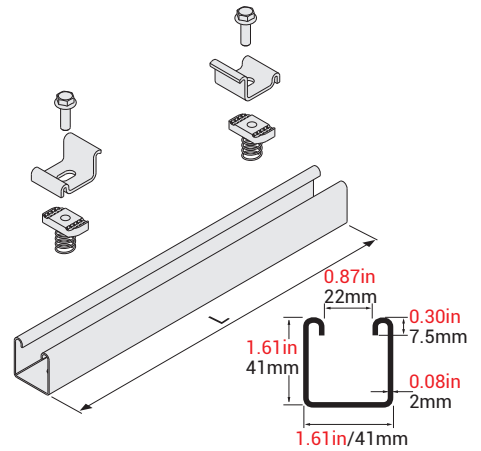
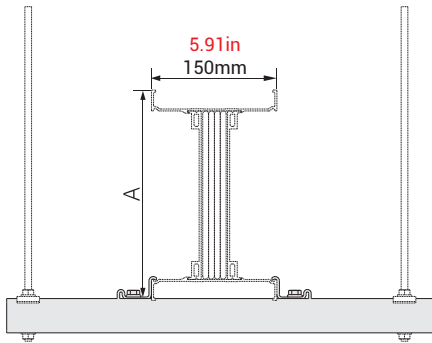

**KX - BRA HANGER SET FOR FLATWISE APPLICATION TO BINRAK (UNISTRUT) CHANNEL**

Al Conductor		Cu Conductor		L		A		Order Code
Rated Current	Busbar Code	Rated Current	Busbar Code	(inch)	(mm)	(inch)	(mm)	
400	04	-	-	11.81	300	3.25	82.5	3025372
550	05	630	06			3.58	91	
-	-	800	08			3.78	96	
630	06	-	-			4.17	106	
-	-	1000	10			4.37	111	
800	08	1250	12	5.16	131	3025373		
1000	10	1350	14	5.75	146			
1300	13	1600	16	13.78	350	6.93	176	3025373
1600	17	2000	20	15.75	400	8.70	221	3025374
2000	20	-	-	17.72	450	11.06	281	3025375

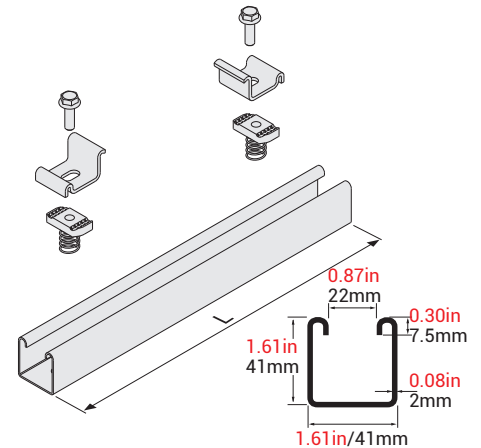
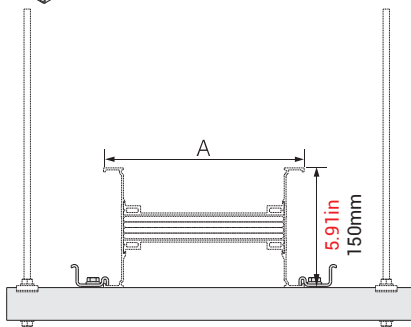

■ The dimensions given above are minimum values. ■ All measures are given in inch. /mm



## Supports

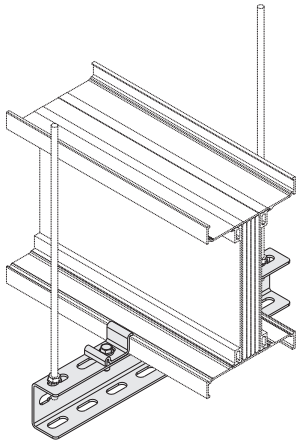

**KX - UT HANGER SET  
FOR EDGEWISE  
APPLICATION  
TO NPU CHANNEL**

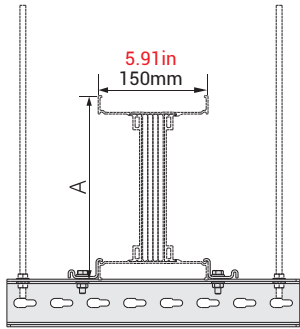
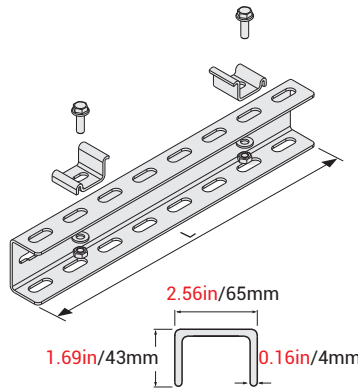

Al Conductor		Cu Conductor		L		A		Order Code
Rated Current	Busbar Code	Rated Current	Busbar Code	(inch)	(mm)	(inch)	(mm)	
400	04	-	-	13.78	350	3.25	82.5	3025348
550	05	630	06			3.58	91	
-	-	800	08			3.78	96	
630	06	-	-			4.17	106	
-	-	1000	10			4.37	111	
800	08	1250	12			5.16	131	
1000	10	1350	14			5.75	146	
1300	13	1600	16			6.93	176	
1600	17	2000	20			8.70	221	
2000	20	-	-			11.06	281	
-	-	2000	22			9.92	252	
-	-	2500	26			11.10	282	
2500	25	3200	32			13.46	342	
-	-	4000	40			17.80	452	
3200	33	-	-			19.37	492	
4000	40	-	-			23.31	592	
-	-	5000	50	21.73	552			
-	-	6000	60	26.46	672			
5000	50	-	-	28.82	732			

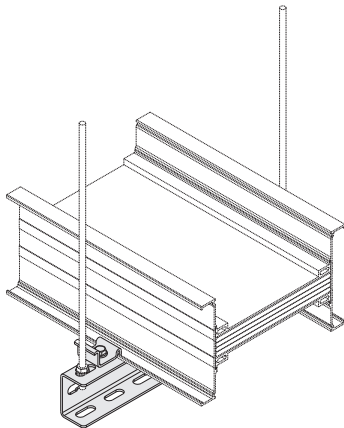

**KX - UT HANGER SET  
FOR FLATWISE  
APPLICATION  
TO NPU CHANNEL**

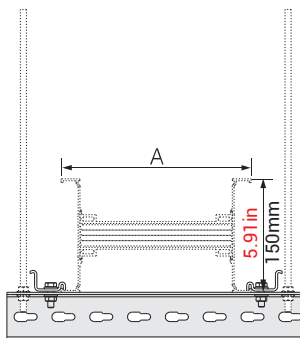
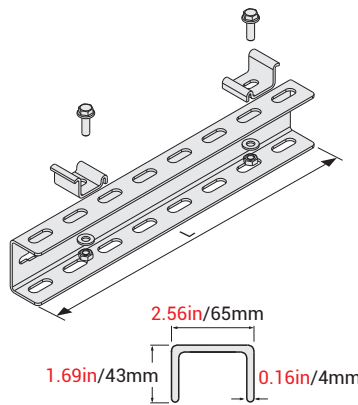

Al Conductor		Cu Conductor		L		A		Order Code
Rated Current	Busbar Code	Rated Current	Busbar Code	(inch)	(mm)	(inch)	(mm)	
400	04	-	-	11.81	300	3.25	82.5	3025347
550	05	630	06			3.58	91	
-	-	800	08			3.78	96	
630	06	-	-			4.17	106	
-	-	1000	10	4.37	111			
800	08	1250	12	5.16	131			
1000	10	1350	14	5.75	146	3025348		
1300	13	1600	16	6.93	176	3025349		
1600	17	2000	20	8.70	221			
2000	20	-	-	11.06	281	3025350		
-	-	2000	22	9.92	252			
-	-	2500	26	11.10	282			
2500	25	3200	32	13.46	342	3025352		
-	-	4000	40	17.80	452			
3200	33	-	-	19.37	492	3025354		
4000	40	-	-	23.31	592			
-	-	5000	50	21.73	552			
-	-	6000	60	26.46	672			
5000	50	-	-	28.82	732	3025355		

■ The dimensions given above are minimum values. ■ All measures are given in inch. /mm

## Supports

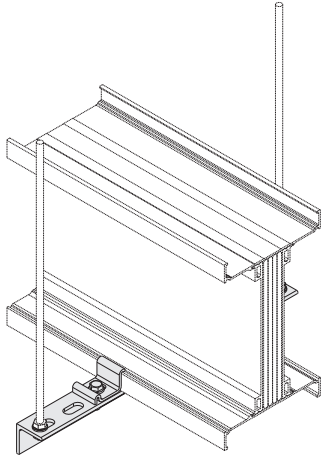

**KX HANGER SET FOR EDGEWISE APPLICATION TO STEEL ANGLE PROFILE**

Al Conductor		Cu Conductor		L		A		Order Code
Rated Current	Busbar Code	Rated Current	Busbar Code	(inch)	(mm)	(inch)	(mm)	
400	04	-	-	13.78	350	3.25	82.5	3025344
550	05	630	06			3.58	91	
-	-	800	08			3.78	96	
630	06	-	-			4.17	106	
-	-	1000	10			4.37	111	
800	08	1250	12			5.16	131	
1000	10	1350	14			5.75	146	
1300	13	1600	16			6.93	176	
1600	17	2000	20			8.70	221	
2000	20	-	-			11.06	281	

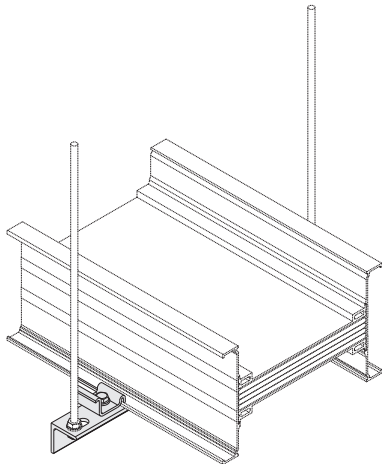
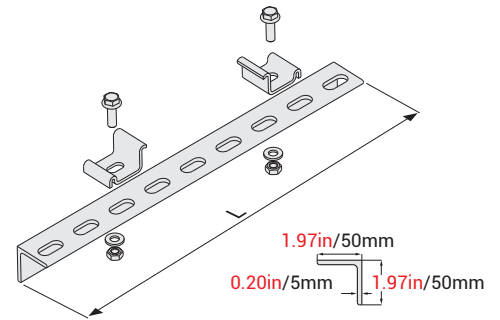
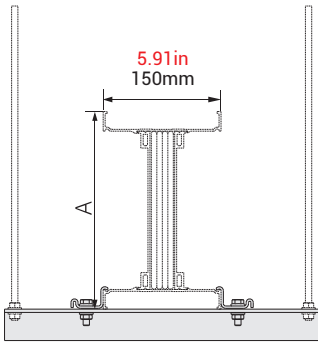

**KX - BRA HANGER SET FOR FLATWISE APPLICATION TO BINRAK (UNISTRUT) CHANNEL**

Al Conductor		Cu Conductor		L		A		Order Code
Rated Current	Busbar Code	Rated Current	Busbar Code	(inch)	(mm)	(inch)	(mm)	
400	04	-	-	11.81	300	3.25	82.5	3025372
550	05	630	06			3.58	91	
-	-	800	08			3.78	96	
630	06	-	-			4.17	106	
-	-	1000	10			4.37	111	
800	08	1250	12	5.16	131	3025374		
1000	10	1350	14	5.75	146			
1300	13	1600	16	13.78	350		6.93	176
1600	17	2000	20	15.75	400		8.70	221
2000	20	-	-	17.72	450		11.06	281

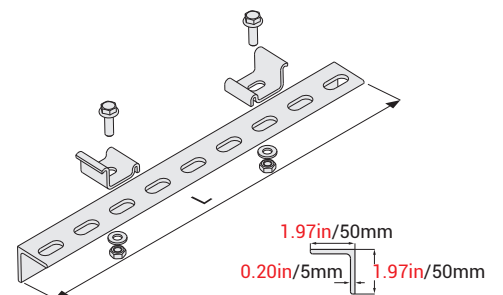
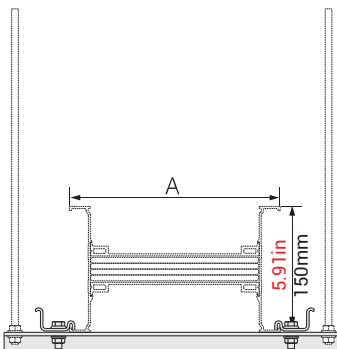

■ The dimensions given above are minimum values. ■ All measures are given in inch. /mm

### Fixing Elements

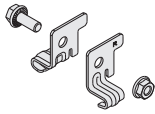

### Supports

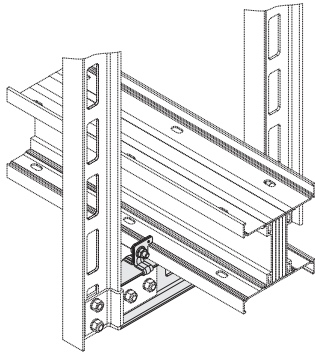

**KX - IDY TWO-WAY  
FOR EDGEWISE  
APPLICATION  
TO NPI CHANNEL**

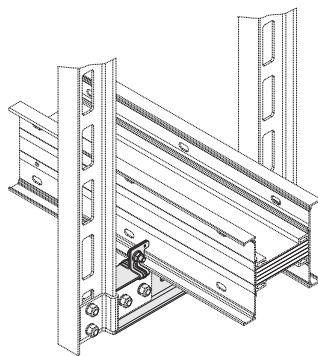
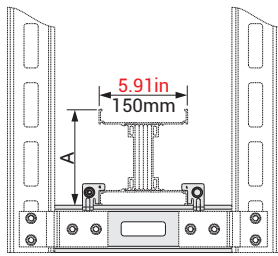
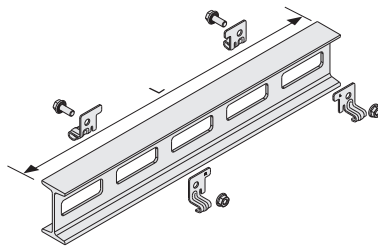

**KX - IDY TWO-WAY  
FOR FLATWISE  
APPLICATION  
TO NPI CHANNEL**

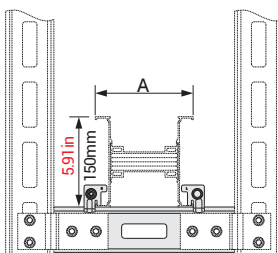
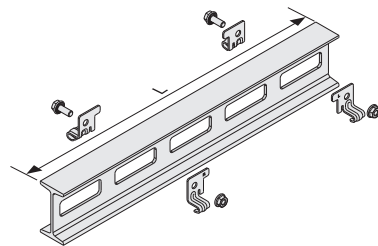

Description	Code
KX IDY Support Set	2054590

Al Conductor		Cu Conductor		L		A		Order Code
Rated Current	Busbar Code	Rated Current	Busbar Code	(inch)	(mm)	(inch)	(mm)	
400	04	-	-	11.81	350	3.25	82.5	3113547
550	05	630	06			3.58	91	
-	-	800	08			3.78	96	
630	06	-	-			4.17	106	
-	-	1000	10			4.37	111	
800	08	1250	12			5.16	131	
1000	10	1350	14			5.75	146	
1300	13	1600	16			6.93	176	
1600	17	2000	20			8.70	221	
2000	20	-	-			11.06	281	
-	-	2000	22			9.92	252	
-	-	2500	26			11.10	282	
2500	25	3200	32			13.46	342	
-	-	4000	40			17.80	452	
3200	33	-	-			19.37	492	
4000	40	-	-			23.31	592	
-	-	5000	50			21.73	552	
-	-	6000	60			26.46	672	
5000	50	-	-			28.82	732	

Al Conductor		Cu Conductor		L		A		Order Code			
Rated Current	Busbar Code	Rated Current	Busbar Code	(inch)	(mm)	(inch)	(mm)				
400	04	-	-	11.81	300	3.25	82.5	3113547			
550	05	630	06			3.58	91				
-	-	800	08			3.78	96				
630	06	-	-			4.17	106				
-	-	1000	10			4.37	111				
800	08	1250	12			5.16	131				
1000	10	1350	14			5.75	146				
1300	13	1600	16			6.93	176				
1600	17	2000	20			15.75	400		8.70	221	3113548
2000	20	-	-			19.69	500		11.06	281	3113549
-	-	2000	22	9.92	252						
-	-	2500	26	11.10	282						
2500	25	3200	32	13.46	342						
-	-	4000	40	27.56	700	17.80	452	3134127			
3200	33	-	-			19.37	492				
4000	40	-	-			23.31	592				
-	-	5000	50	35.43	900	21.73	552	3113553			
-	-	6000	60			26.46	672				
5000	50	-	-	28.82	732						

■ The dimensions given above are minimum values. ■ All measures are given in inch. /mm

### Supports

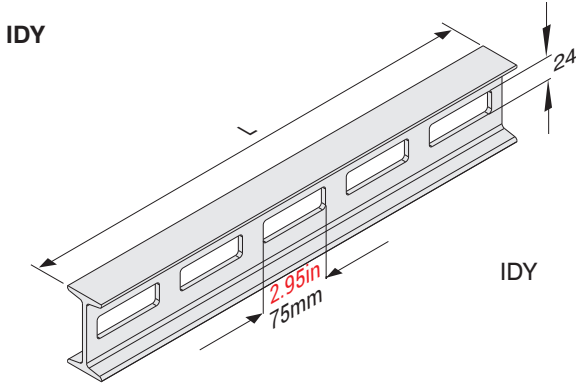

IDY

IDY

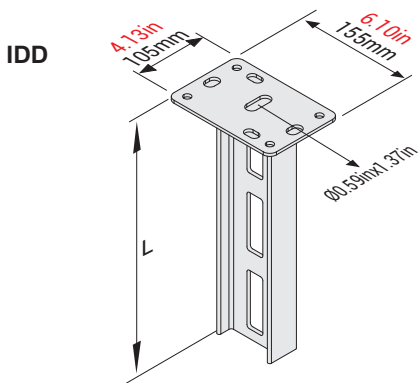

IDD

IDD

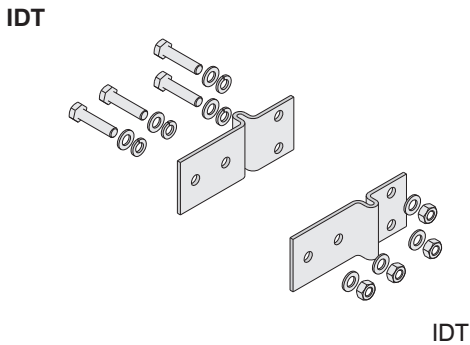

IDT

IDT

Description	L		Code
	(inch)	(mm)	
IDY 300	11.81	300	3008242
IDY 400	15.75	400	3008290
IDY 500	19.69	500	3008289
IDY 600	23.62	600	3008288
IDY 700	27.56	700	3008287
IDY 800	31.50	800	3008286
IDY 900	35.43	900	3008285
IDY 1000	39.37	1000	3008284
IDY 1100	43.31	1100	3008283
IDY 1200	47.24	1200	3008282
IDY 1300	51.18	1300	3008236
IDY 1400	55.12	1400	3008281
IDY 1500	59.06	1500	3008280
IDY 1600	62.99	1600	3008241
IDY 1700	66.93	1700	3008240
IDY 1800	70.87	1800	3008239
IDY 1900	74.80	1900	3008238
IDY 2000	78.74	2000	3008237
IDD 300	11.81	300	3008314
IDD 400	15.75	400	3008313
IDD 500	19.69	500	3008312
IDD 600	23.62	600	3008311
IDD 700	27.56	700	3008310
IDD 800	31.50	800	3008309
IDD 900	35.43	900	3008308
IDD 1000	39.37	1000	3008307
IDD 1100	43.31	1100	3008306
IDD 1200	47.24	1200	3008305
IDD 1300	51.18	1300	3008304
IDD 1400	55.12	1400	3008303
IDD 1500	59.06	1500	3008302
IDD 1600	62.99	1600	3008301
IDD 1700	66.93	1700	3008300
IDD 1800	70.87	1800	3008299
IDD 1900	74.80	1900	3008298
IDD 2000	78.74	2000	3008297
IDT Support Fitting	-	-	3008279

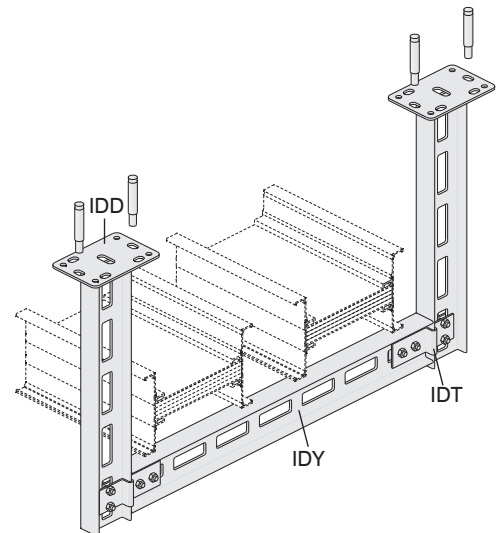

■ Please call us for non-standard components.

## Supports

### UPY

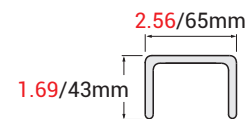
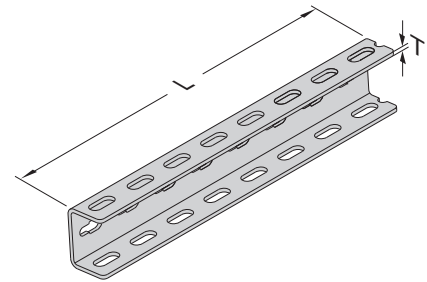
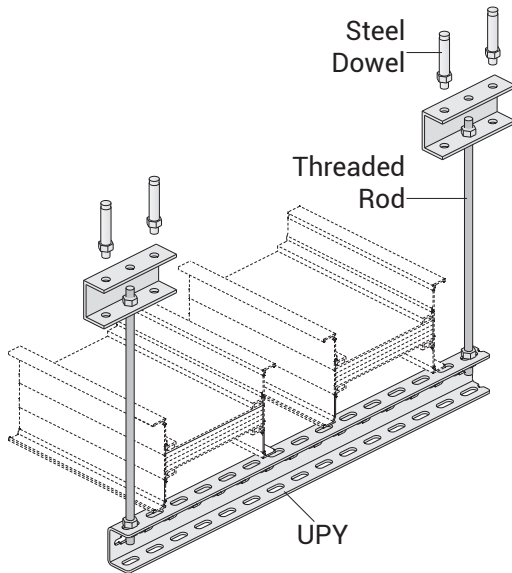

Description	T		L		Code
	(inch)/(mm)	(inch)	(inch)	(mm)	
UPY 300	0.16 / 4	11.81	300	3004487	
UPY 400	0.16 / 4	15.75	400	3004489	
UPY 500	0.16 / 4	19.69	500	3004491	
UPY 600	0.16 / 4	23.62	600	3004493	
UPY 700	0.16 / 4	27.56	700	3004495	
UPY 800	0.16 / 4	31.50	800	3004496	
UPY 900	0.16 / 4	35.43	900	3004497	
UPY 1000	0.16 / 4	39.37	1000	3004498	
UPY 1100	0.16 / 4	43.31	1100	3004499	
UPY 1200	0.16 / 4	47.24	1200	3004500	
UPY 1500	0.16 / 4	59.06	1500	3004503	

■ Please call us for non-standard components.



## Supports

### UDY

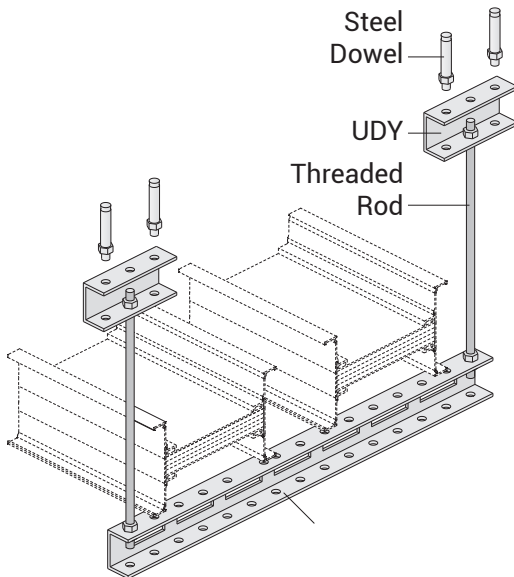
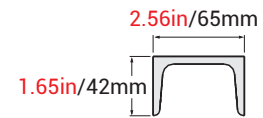
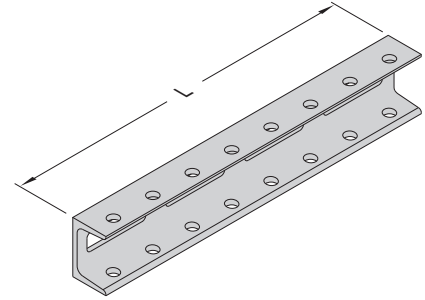
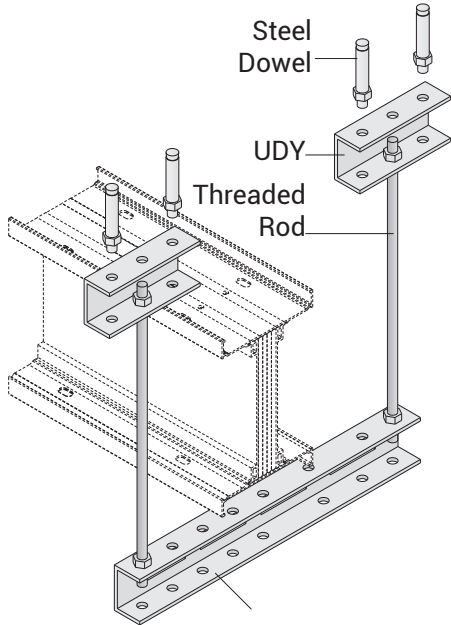

Description	L		Code
	(inch)	(mm)	
UDY 300	11.81	300	3008023
UDY 400	15.75	400	3008024
UDY 500	19.69	500	3008025
UDY 600	23.62	600	3008026
UDY 700	27.56	700	3008027
UDY 800	31.50	800	3008028
UDY 900	35.43	900	3008029
UDY 1000	39.37	1000	3008030
UDY 1100	43.31	1100	3008031
UDY 1200	47.24	1200	3008032
UDY 1300	51.18	1300	3008033
UDY 1400	55.12	1400	3008034
UDY 1500	59.06	1500	3008035
UDY 1600	62.99	1600	3008036
UDY 1700	66.93	1700	3008037
UDY 1800	70.87	1800	3008038
UDY 1900	74.80	1900	3008039
UDY 2000	78.74	2000	3008040

■ Please call us for non-standard components.

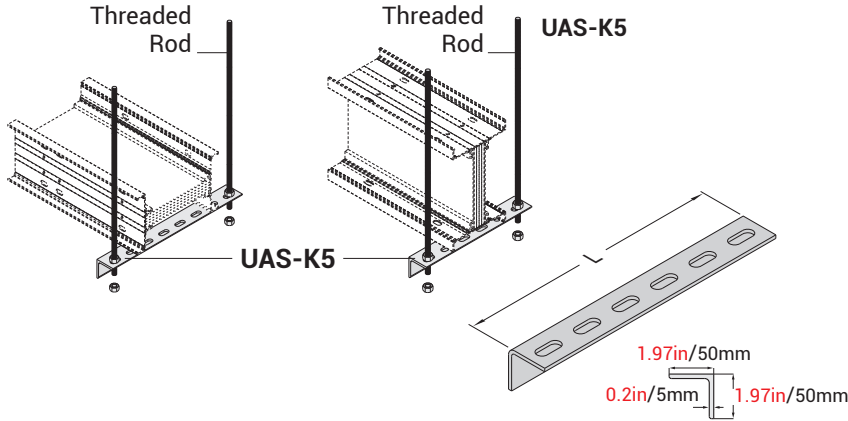

### Supports

Description	L		Code
	(inch)	(mm)	
UAS-K5 SUPPORT (1)	7.87	200	3005324
UAS-K5 SUPPORT (2)	9.84	250	3005323
UAS-K5 SUPPORT (3)	11.81	300	3005322
UAS-K5 SUPPORT (4)	13.78	350	3005321
UAS-K5 SUPPORT (5)	15.75	400	3005320
UAS-K5 SUPPORT (6)	19.69	500	3005319
UAS-K5 SUPPORT (7)	23.62	600	3005318
UAS-K5 SUPPORT (8)	27.56	700	3005317
UAS-K5 SUPPORT (9)	43.31	1100	3005316

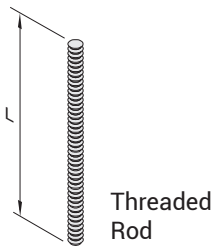

Threaded Rod



Extension Unit

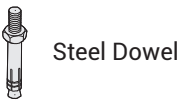

Steel Dowel

Diameter of the hole to be drilled  
M10.....Ø0.55in  
M12.....Ø0.63in



Steel Nut

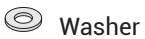

Washer

### Connection Units

Description	L		Code
	(inch)	(mm)	
BRA 12-05 Threaded Rod (M10)	19.69	500	5000037
BRA 12-10 Threaded Rod (M10)	39.37	1000	5000032
BRA 14-05 Threaded Rod (M12)	19.69	500	5000026
BRA 14-10 Threaded Rod (M12)	39.37	1000	5000034
BRA 13 Extension Unit (M10)	-	-	1004312
BRA 13 Extension Unit (M12)	-	-	1004282
BRA 9 Steel Dowel (M10)	-	-	5000023
BRA 9 Steel Dowel (M12)	-	-	5000022
M10 Steel Nut	-	-	1000522
M12 Steel Nut	-	-	1000964
M10 Washer	-	-	1000504
M12 Washer	-	-	1000505

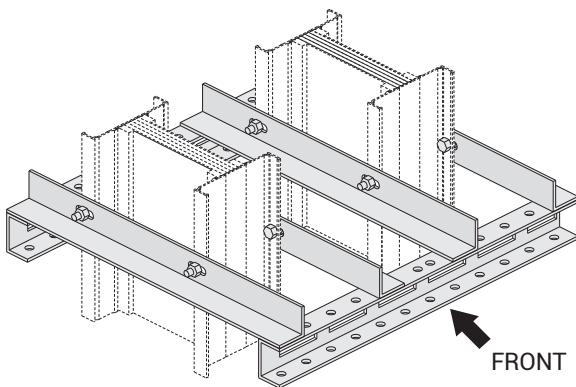

Vertical Riser Application  
Sample Order Hanging  
(Special to project)

■ Please call us for non-standard components.

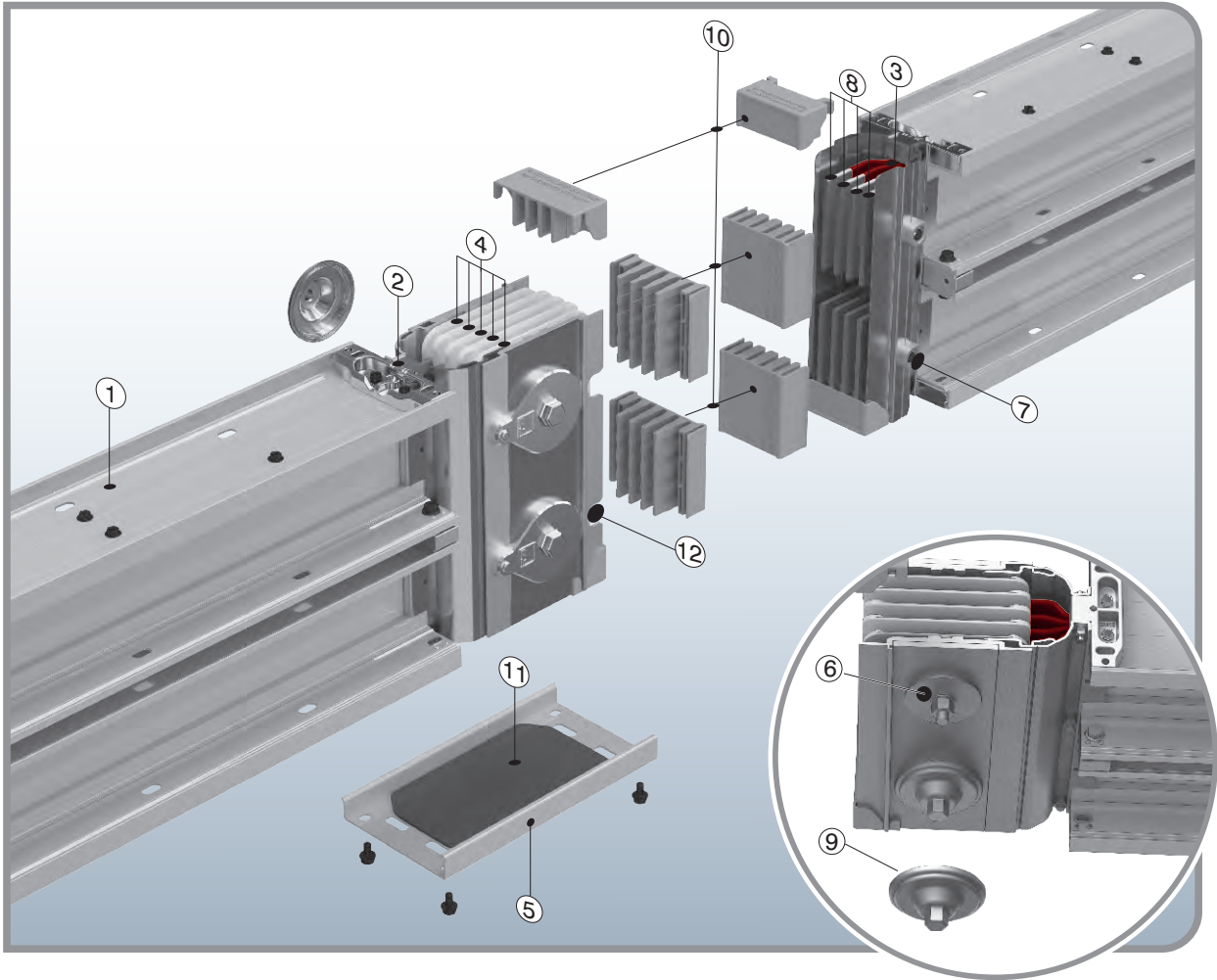

1. Extruded Aluminium Housing
2. PE Fixing Piece
3. Insulation Layers (Epoxy+B class polyester film)
4. Joint Insulators
5. Joint Cover
6. Belleville
7. Alignment Pin (removable)
8. Conductors
9. IP55 Nut Locking Piece
10. Protection Plastic
11. IP55 Joint Cover Gasket
12. Alignment Pin Slot

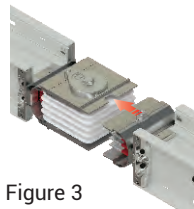

Figure 3

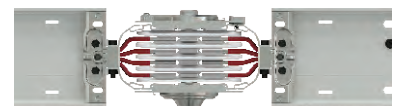

Figure 4

Joint assembly

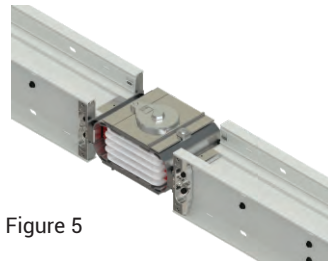

Figure 5

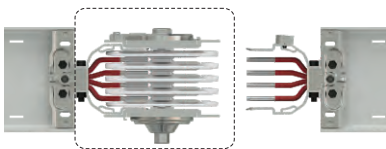

Figure 1 Block Joint

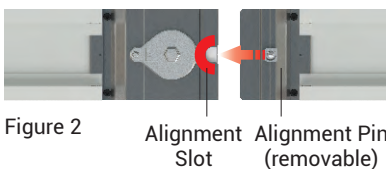

Figure 2 Alignment Slot Alignment Pin (removable)

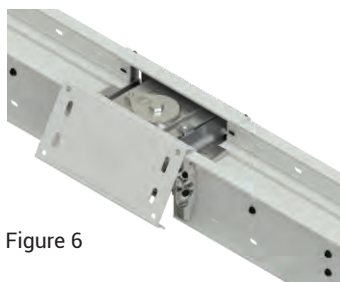
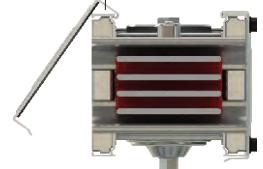

Figure 6

The joint cover is closed by leverage.



■ Please call us for non-standard components.

## ►► Measuring a Special Length

After installation of standard busbar 9.84ft/3m lengths, you will be in need of special lengths which are smaller than 9.84ft/3m. The minimum length for these special elements can be 13.78in/350mm. Please measure the lengths of these modules as shown below.

Length A is measured between housing of 2 busbars in mm/inch. A, The special length is calculated by deducting 9.84in/250mm from this measured length.

$X = A - 9.84\text{in}$  (250mm) X=Length of Special Busbar (The busbar module will be manufactured as per X value.)

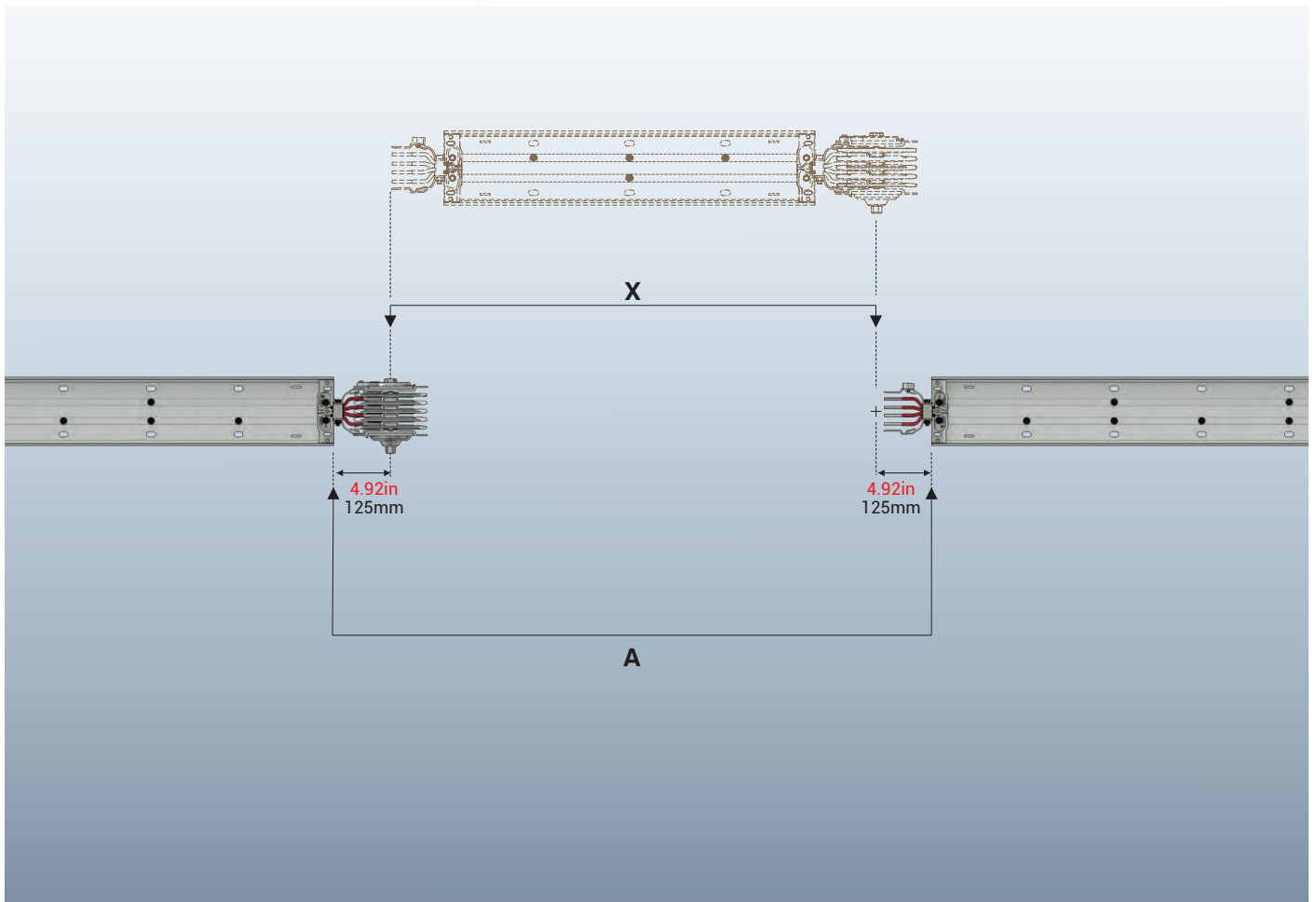

■ Please call us for non-standard components.

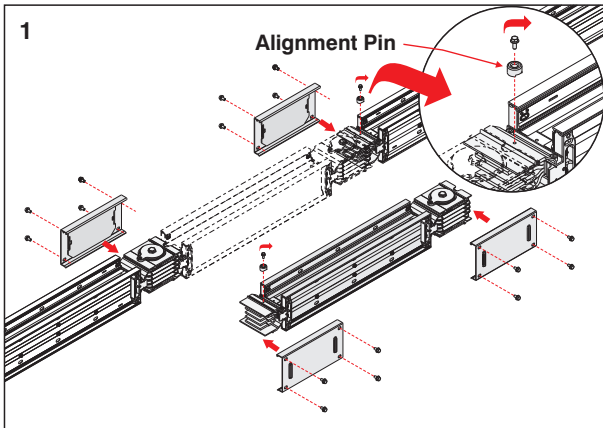

1- Remove Alignment Pin on the busbar, without block joint.

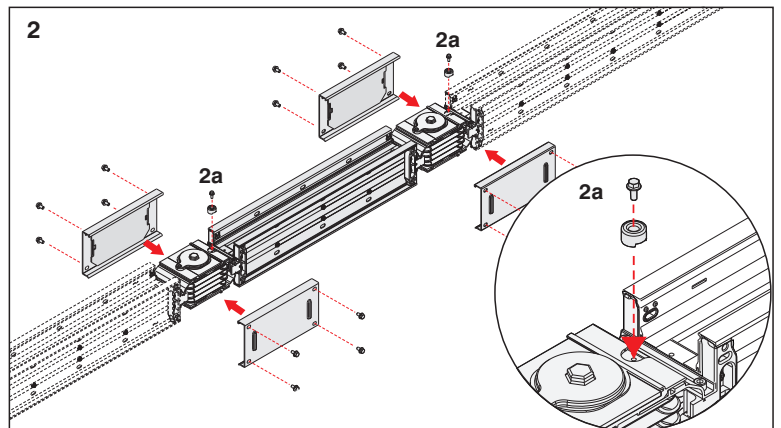

2- Insert the piece aligning conductors correctly, Fix back the Alignment pin.

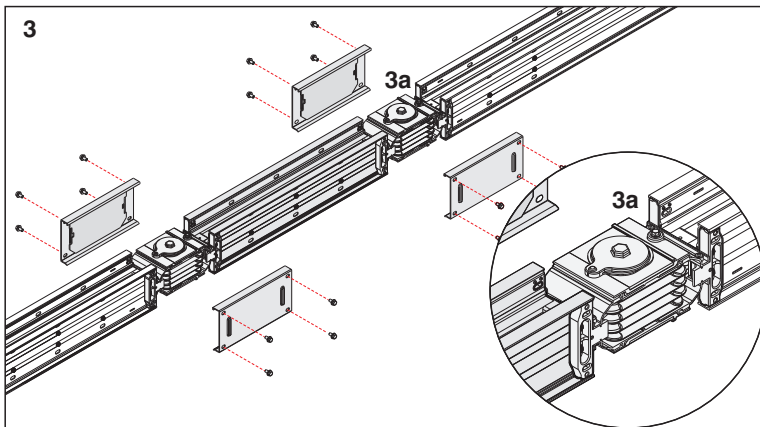

3- Make sure busbar piece is aligned according to alignment pin.

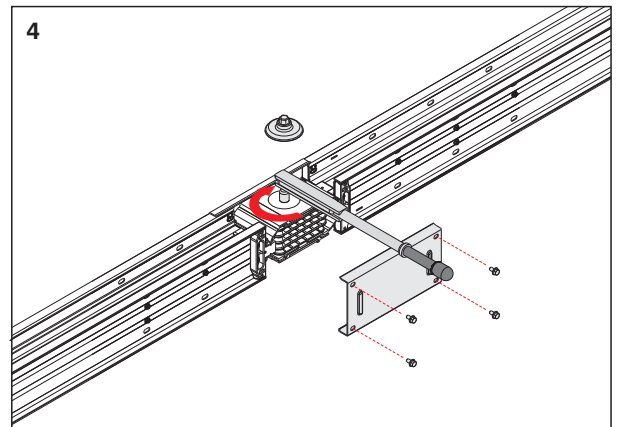

4- Fix one of the joint cover to stabilize joint. Apply 61.2lb/60lbft to the main bolt.

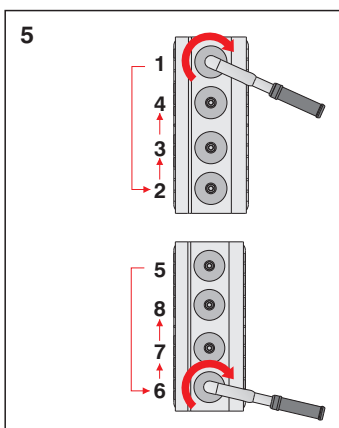

5- If there are more than one bolt for the same phase, bolts shall be tighten approximately at 14.7lb as per above sequence. Then 61.2lb shall be applied at final torque with the same sequence.

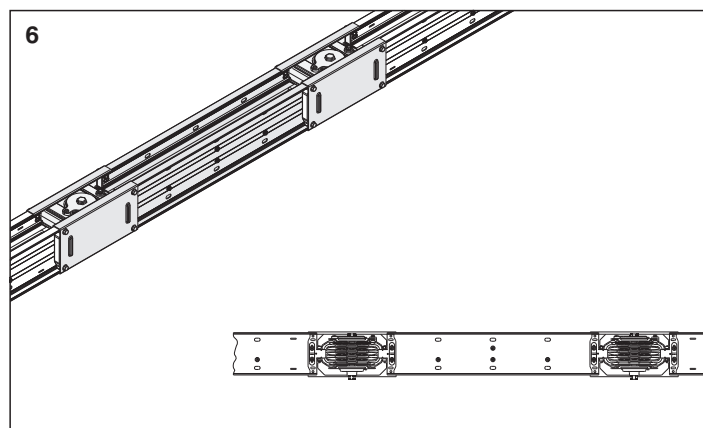

6- Fix the remaining joint cover.

Note: If the final joint cover does not close correctly, it indicates the busbar is not completely aligned. Release the bolts and reapply the sequence from figure 4 to complete the joint.



## CERTIFICATE OF COMPLIANCE

Certificate Number 20190816-E505448  
Report Reference E505448-20190321  
Issue Date 2019-AUGUST-16

**Issued to:** EAE ELEKTRIK ASANSOR END INS SAN VE TIC A S  
Akcaburgaz Man 119 Sk 10, Esenyurt  
34510 Istanbul TURKEY

**This certificate confirms that  
representative samples of**

**BUSWAYS AND ASSOCIATED FITTINGS**

Busway, series KXC-III followed by a two number designation between 06 through 60, followed by additional alpa numeric designations as noted in the nomenclature.  
Busway, series KXA-III followed by a two number designation between 04 through 51, followed by additional alpa numeric designations as noted in the nomenclature

Have been investigated by UL in accordance with the Standard(s) indicated on this Certificate.

**Standard(s) for Safety:** UL 857 BUSWAYS  
CSA C22.2 NO. 27-09 BUSWAYS

**Additional Information:** See the UL Online Certifications Directory at <https://iq.ulprospector.com> for additional information.

This *Certificate of Compliance* does not provide authorization to apply the UL Mark. Only the UL Follow-Up Services Procedure provides authorization to apply the UL Mark.

Only those products bearing the UL Mark should be considered as being UL Certified and covered under UL's Follow-Up Services.

Look for the UL Certification Mark on the product.

  
Bruce Mahrenholz, Director North American Certification Program  
UL LLC

Any information and documentation involving UL Mark services are provided on behalf of UL LLC (UL) or any authorized licensee of UL. For questions, please contact a local UL Customer Service Representative at [ul@ul.com](mailto:ul@ul.com) or <http://www.ul.com>



**KX III-UL 400A – 6000A COMPACT BUSBAR PRODUCT FEATURES**

**KX III-UL** busbar system allows users to distribute electrical energy safely with 46 years of experience in design and manufacturing of busbar systems. **KX III-UL**, features flexible power supply, short installation time, superior heat dissipation and electrical characteristics. Where shown on plans, furnish and install a totally enclosed, low-impedance busbar system of the indicated ratings with all necessary fittings, power takeoffs, hanging devices and accessories.

**1- Standards & Certification**

- **KX III-UL** Busbar system has been designed and manufactured as per UL 857 standard, which requires below listed tests. Each busbar rating has been type tested individually and comply with recent UL 857 standards for all type tests and certified by independent authorized testing laboratory as UL including below test:
- Compliant for: CUL Listing
- Compliant for: National Electric Code (NEC) Article 364 – Busbars 19
- Compliant: NEMA AB1, Molded Case Circuit Breakers and Molded Case Switches
- Compliant: NFPA 70 – National Fire Protection Agency
- EAE has ISO 9001, ISO 14001, OSHA 18001, ISO 27001 and ISO 17025 certifications.
- All the required type tests for each rating according to IEC 61439-6 and certified with 3rd Party.
- Compliant: IEC 60364-1 Low-voltage electrical installations
- **KX III-UL** Busbar has high flame resistance and circuit integrity properties under fire conditions according to IEC 60331, BS 6387, BS 8491 standards including joints and tap-off boxes.

**2- Electrical Characteristics**

- **KX III-UL** Busbar systems nominal voltage is 600 V.
  - Operating Frequency: 50/60 Hz
  - 6 Cycle RMS Symmetrical Short Circuit Rating shall be:
- For Aluminium Conductors;
- 400-630A : 50kA
  - 800-1300A : 65kA
  - 1600-2000A : 100kA
  - 2500A : 125kA
  - 3200A : 200kA
  - 4000A : 150kA
  - 5000A : 200kA

For Copper Conductors;

- 630-1000A : 65kA
- 1250-2000A: 125kA
- 2000-6000A: 200kA

- Position: 100% rating for any horizontal or vertical orientation.
- The maximum hot-spot temperature rise at any point in the busbar at continuous rated load shall not exceed 131 °F

**3- Components****3.1- Housing**

- **KX III-UL** Busbar system has "Sandwich-Compact" structure. Conductors are packed and placed into the housing without leaving air gap in order to provide low reactance.
- The housing shall be RAL7035-Electrostatic painted extruded aluminum to provide maximum protection against corrosion from water and other contaminants normally encountered during construction.
- The busbar housing shall be of 100% aluminum construction to reduce hysteresis and eddy current losses.
- Busbar housing shall have optional powder coating finish if required per project design,
- "Compact structure of the housing has been provided by M6 screws applied at every 7.48 in along the entire length.
- The sandwich-compact structure continues at the plug-in points too. There isn't any air gap between conductors at the plug-in points.
- The housing material and paint are selected with non-propagating properties.

**3.2- Conductors**

- Conductors: Individual isolated and insulated. Aluminum or Copper conductors are epoxy coated. All phase and neutral conductors joints and contact surfaces are plated tin (optimal Silver).
- Straight sections of feeder busbar can be supplied in any length, from a 12.00-inch (350 mm) minimum to a 10-feet (3048 mm) maximum
- Bus bars shall be suitably plated at all joints and contact surfaces.
- **KX III-UL** busbar system has aluminum conductors between 400A – 5000A,
- **KX III-UL** busbar system has copper conductors between 630A – 6000A,
- **KX III-UL** busbar system has the following number of conductors and wire configuration;
- A. 4½ Conductors: (4 full size conductors + PE (50% earth conductor + housing)).
- b. 5 Conductors: (4 full size conductors + PE (100% earth conductor + housing)).
- c. 6 Conductors: (5 full size conductors ( + PE (100% earth conductor + housing)).
- Phase conductors and neutral conductor have the same cross-section and they are insulated.
- Aluminum conductors are EC grade aluminum.
- The conductors may be ordered in copper (98% conductivity), Aluminium (58% conductivity).

**3.3- Insulation**

- Insulation system is suitable for 600 V continuous operation.
- Specially formulated Class B epoxy insulation has been applied as insulation material which provides high insulation resistance and high peak temperature resistance.
- The insulation process apply is the spray insulation process which produces uniform application of the epoxy powder over the entire conductor bar. It is further enhanced by inline filter process and magnetic separator that help to eliminates contaminants common to fluidized bed systems.
- Epoxy is UL V0 class and halogen and toxic free properties.
- All insulators must be UL recognized.

**3.4- Joint Structure**

- **KX III - UL** Busbar, ensures contact pressure at the joint by special EAE Belleville spring washers.
- All parts of the joint structure are plated with tin against contact losses due to corrosion in order to get safe and reliable earth connections and have very low resistance values entire length.
- It shall be possible to make up a joint from one side in the event the busbar is installed against a wall or ceiling. The joint shall be so designed as to allow removal of any length without disturbing adjacent lengths.

**3.5- Accessories and Components**

- All system components including Tees, flanges, Reducers, Expansion joints and Elbows etc. shall be of the same material from the same manufacturer.
- End pieces and end caps will be provided to install at the ends of each line.
- **KX III-UL** Busbar system has all necessary accessories (elbows, offsets, panel-transformer connections, reductions, etc.) EAE supply special dimensioned units in short time, if the project conditions require.
- For horizontal runs, a horizontal expansion unit will be used at every 40m and at the building expansions.
- For vertical applications, a vertical expansion unit will be used at every floor. Busbar system must be rigidly fixed by supports at every floor.
- Horizontal runs of busbar shall be UL Listed for hanging on 10-foot (3.05 meters) centers in any position. Vertical riser runs of busbar shall be supported with rigid and/or spring hangers in positions indicated on plans (max 16'4.88 meters) centers.

Component List	Item	Component	Quantity
Please duplicate this page for your own use.			

Company :  
Project :  
Project No :

Prepared by  
Name :  
Date :  
Signature :



[www.eaelectric.com](http://www.eaelectric.com)

47

Component List		Quantity
Item	Component	

Company :	Name :	Prepared by
Project :	Date :	
Project No :	Signature :	

Please duplicate this page for your own use.

AN  
M  
R  
IA  
AN  
ME  
S  
G  
-G  
RIE  
NIC  
A  
N  
JM  
(EN

# PRODUCT TYPES



## BUSBAR ENERGY DISTRIBUTION SYSTEMS

---



## CABLE TRAYS

---



## TROLLEY BUSBAR ENERGY DISTRIBUTION SYSTEMS

---



## INDOOR SOLUTIONS

---



## SUPPORT SYSTEMS

---

Please visit our website for the updated version of our catalogues.  
[www.eaelectric.com](http://www.eaelectric.com)





**EAE USA**  
56 Perimeter Center East  
Suite#430 Atlanta, GA  
30346 USA  
Phone : +1(770)-6964803  
Email : info@eaeusa.us

**EAE Elektrik A.S.Head Office**  
Akcaburgaz Mahallesi,  
3114. Sokak, No:10 34522  
Esenyurt - Istanbul - TURKEY  
Tel: +90 (212) 866 20 00  
Fax: +90 (212) 886 24 20

**EAE Elektrik Busbar Factory**  
Makine Ihtisas Organize Sanayi  
Bolgesi Mahallesi, 6. Cadde,  
8. Sokak, No:6 41455  
Dilovası - Kocaeli - TURKEY  
Tel: +90 (262) 502 05 65  
Fax: +90 (262) 502 05 70

Please visit our website for the updated version of our catalogues.  
[www.eaeelectric.com](http://www.eaeelectric.com)



Catalogue 59 / Rev 02 0000 pcs. 13/10/2022  
D.S.

EAE has full right to make any revisions or changes on this catalogue without any prior notice.

