

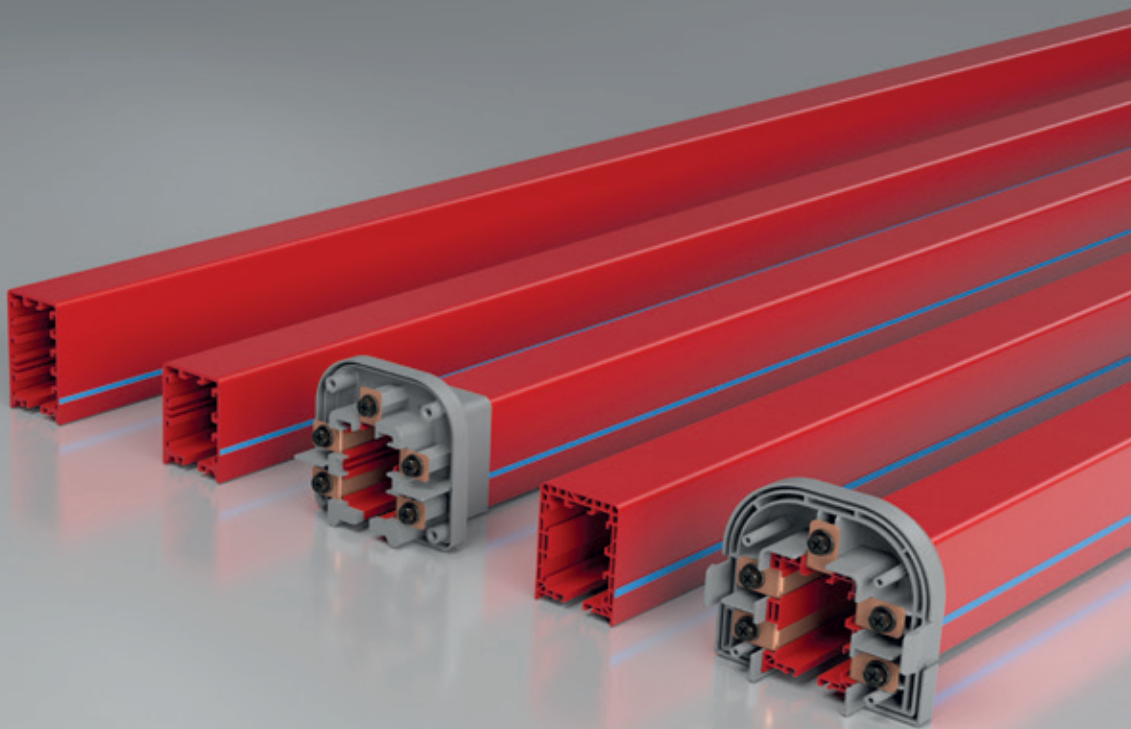

E-LINE TROLLEY BUSBAR

Trolley Busbar Systems



E-LINE TROLLEY BUSBAR

Please visit our website for the updated version of our catalogues.
www.eaelectric.com



EAE Group in numbers;



1973
year of foundation

Founded in 1973, EAE Elektrik A.S. being the parent company of EAE Group is a worldwide manufacturer of electrical products.

Founded : in 1973
Closed Manufacturing Area : 280.000m²
Range of Products : Busbar Power Distribution Systems
Lighting Busbar Systems
Cable Tray Systems
Underfloor Trunking
Trolley Busbar Systems



280.000m²
closed manufacturing
area

Companies : EAE Elektrik
EAE Aydınlatma
EAE Elektroteknik
EAE Teknoloji
EAE Makina



5
manufacturing
plants

Number of Plants : 5

“Lean Production” and “Innovative and Customer Driven Product Development” approaches are the key values utilized in designing and manufacturing the product families in compliance with ISO 9001, ISO 14001, OHSAS 18001 and ISO 27001.



3
R&D Centers

EAE Elektrik A.S. busbar products are certified by KEMA/DEKRA (Holland), KEMA - KEUR, UL classified laboratories as per IEC 61439-1/6 standards.



100+
countries of export



• Bridge Cranes



• Monorail Systems

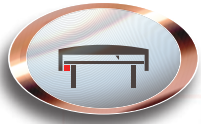

• Textile Cutting and Spreading Tables



• AS/RS Storage Systems



• Moving Ceiling and Door Systems



• Assembly and Test Lines



E-LINE TB

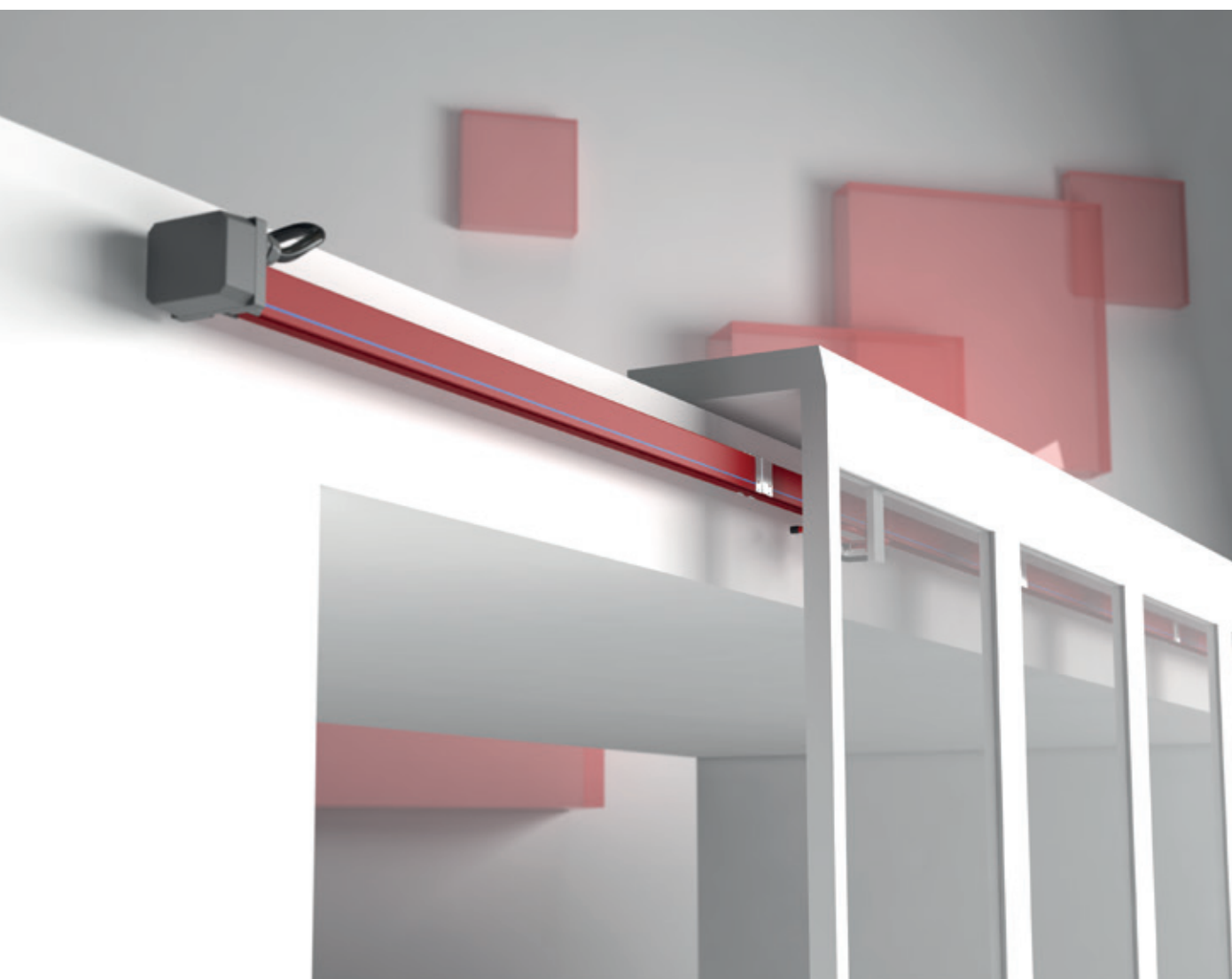

E-LINE TB

Please visit our website for the updated version of our catalogues.
www.eaelectric.com



CONTENTS

▶▶ E-LINE TB

Trolley Busbar Systems	2
Order Code System	3
TB PVC Housing	4
TB Feeder Unit	5-6
TB Repair Zone Module	7
TB Current Collector	8-9
System Components	10-11
Voltage Drop, Calculation Of Feeding Points	12
TB Trolley Busbar Installation Manual	13-14

►► TROLLEY BUSBAR SYSTEMS

- Bridge Cranes
- Monorail Systems
- Textile Cutting and Spreading Tables
- AS/RS Storage Systems
- Moving Ceiling and Door Systems
- Assembly and Test Lines

It consists of copper conductors and current collectors in the C-PVC body. The uninterrupted energy supply and movement of the system is provided by current collectors connected to the system mechanically.

The eliminates the possibilities such as accident, malfunction in energy distribution with suspended and reel cable in conventional systems. Conductors are enclosed in C-PVC housing and personnel safety is maximized.

There is no fixed connection between the conductor housings and the conductors and between the C-PVC housing and the sliding hangers, the necessary expansion opportunity is provided, therefore the expansion element is unrequired.

Cautions:

If it is used in external environments exposed to rain, it is recommended to protect it with a cover such as a canopy.



►► ORDER CODE SYSTEMS

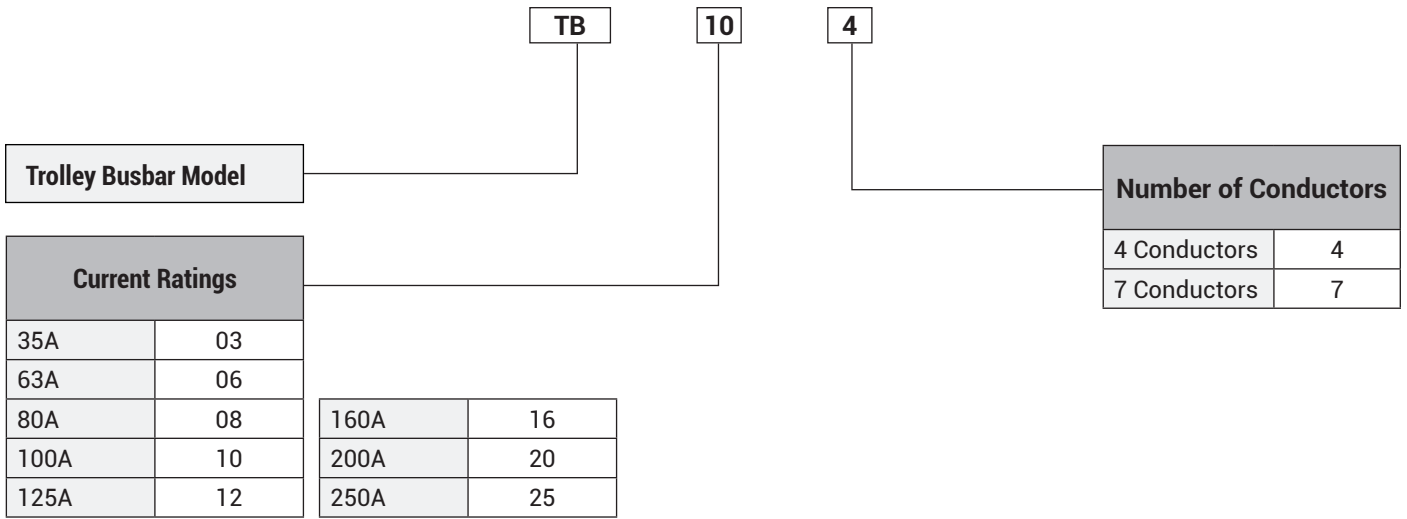

►► TECHNICAL FEATURES

Rated Current (A)		35	63	80	100	125	160	200	250
Conductor Quantities (pcs)		4	4	4	4	4	7	7	7
Rated Voltage (AC) (V)		690	690	690	690	690	690	690	690
Dielectric Properties (kV/mm)		30	30	30	30	30	30	30	30
Frequency (Hz)		50/60	50/60	50/60	50/60	50/60	50/60	50/60	50/60
Resistance (20°C) R ₂₀ (mΩ/m)		1,650	1,680	1,380	0,990	0,730	0,870	0,480	0,410
Resistance (35°C) R ₃₅ (mΩ/m)		1,790	1,920	1,600	1,140	0,860	1,080	0,590	0,510
Reactance X (mΩ/m)		0,220	0,110	0,120	0,190	0,160	0,020	0,100	0,120
Impedance Z (mΩ/m)		1,803	1,923	1,604	1,156	0,875	1,080	0,598	0,524
Standard Length (m)		4	4	4	4	4	4	4	4

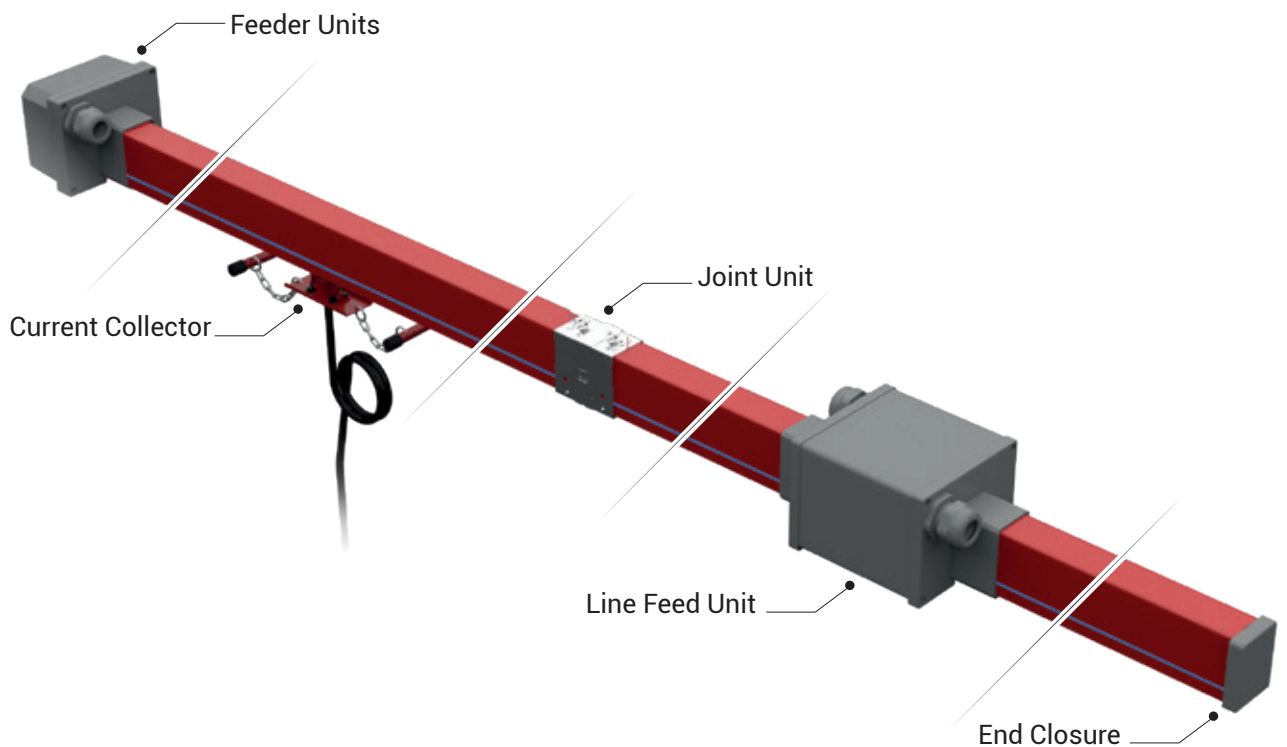

Note: Each sliding hanger should be mounted between 1,30m - 1,50m.

▶▶ TB TROLLEY BUSBAR

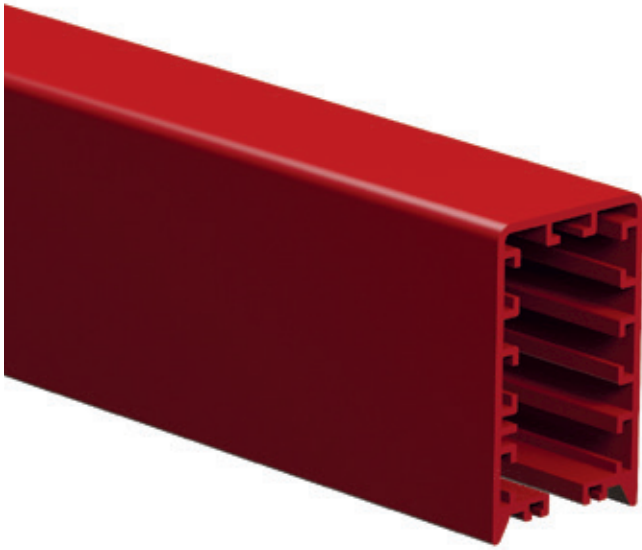

The housing has a structure that can use maximum 7 conductors. There is safety system that prevents the current collector to be fixed inversely.

Continuous Copper Conductors

Electrolytic copper conductors can be applied without interruption at a maximum length of 150 m.

- **Number of Conductors:** 4, 7 Conductors
- **Colour:** Red.
- **Temperature range:** -40°C and +55°C.
- **Standard housing length:** 4 meters.
- **Protection:** Standard IP24, Gasket ile IP44.
- **Non-Flammable Characteristics:** UL 94 V0
- Housing is made of C-PVC and plastic accessories are made of PA6 raw material.
- There is a neutral line on the housing the neutral conductor.

Description	Weight (gr/m)	Order Code
TB Trolley Busbar Housing	1550	2037292

Multiple current combinations with standard C-PVC housing and different usage types can be created.

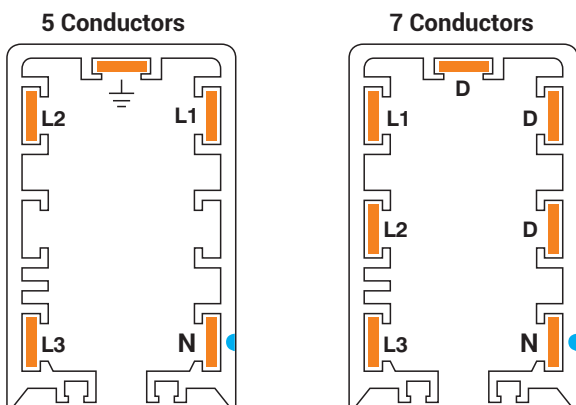
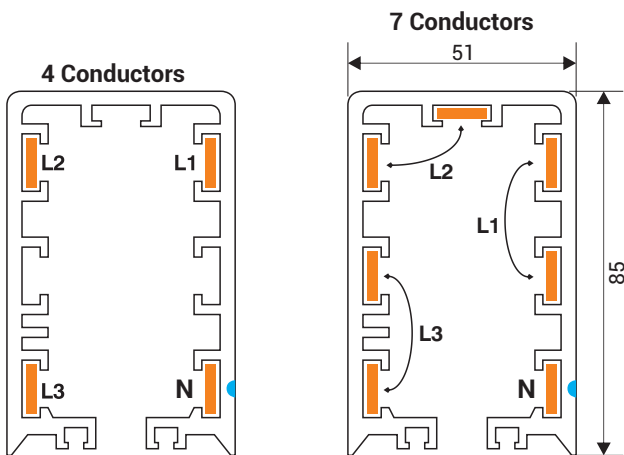

Standard 4 Meters

Model	Conductors Quantity-Current (A)	Weight (gr/m)	Conductor Cross Section (mm ²)	Order Code
TB 034	4P- 35A	1900	4x9,45	3025004
TB 064	4P- 63A	1950	4x10,80	3025005
TB 084	4P- 80A	2000	4x13,50	3025006
TB 104	4P-100A	2250	4x19,50	3025007
TB 124	4P-125A	2450	4x26,00	3025008
TB 167	7P-160A	2400	7x13,50	3025009
TB 207	7P-200A	2750	7x19,50	3025010
TB 257	7P-250A	3150	7x26,00	3025011

Joint plastics are not included in the weight values.
Total weight of the joint plastics and bolts is 0,28 kg.

Radius Trolley Busbar

It has minimum 1.5m radius Trolley Busbar available in vertical axes. Radius Trolley Lines can be applied with maximum 4 conductors.

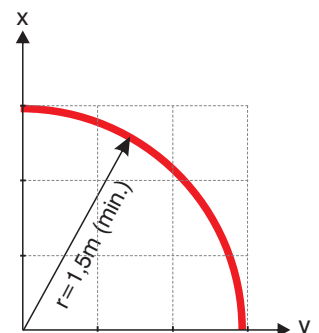

▶▶ TB FEEDER UNITS

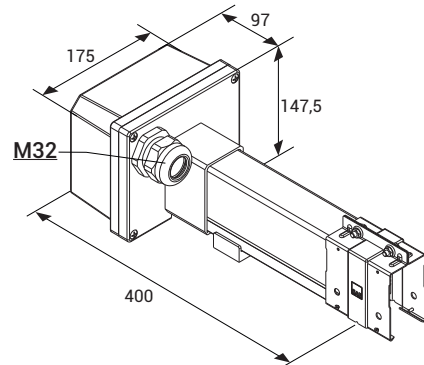
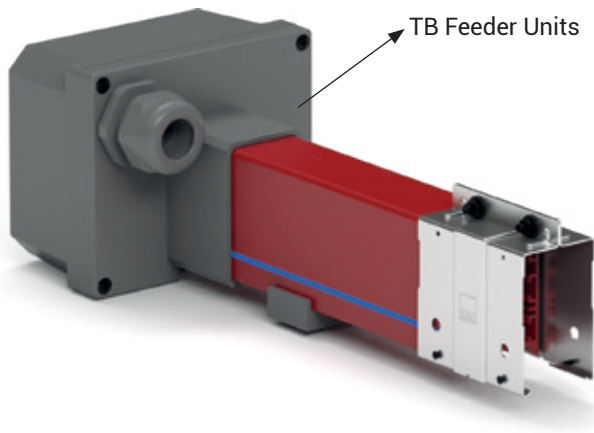

Description	Weight (gr)	Order Code
TB Feeder Units	1100	3025149
TB Feeder Units	650	3188028

Type of the feeder box is selected by calculating the voltage drop and the location of the power supply that shall provide power to the system.

▶▶ TB END CLOSURE

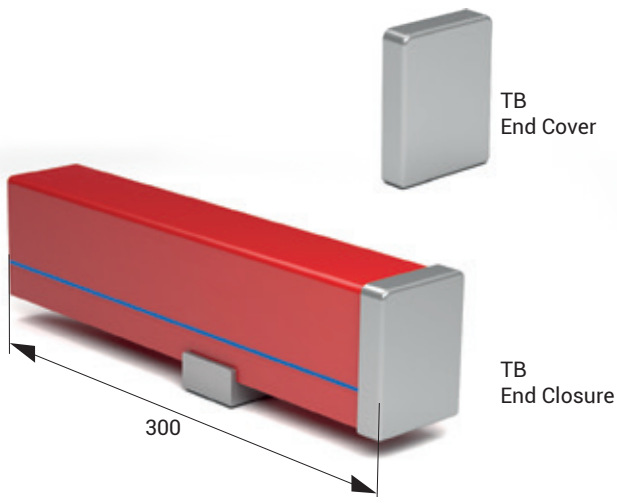

The end closure placed on the end of the busbar line prevents the exposure of the conductors, protects the system, and prevents the current collector from moving out of the housing.

Description	Weight (gr)	Order Code
TB End Closure	550	3025147
TB End Cover	20	1001036

▶▶ TB JOINT UNIT

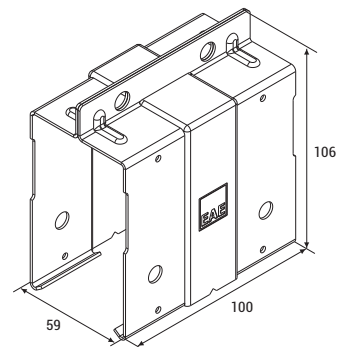
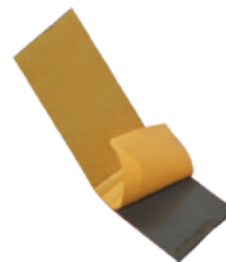

Description	Weight (gr)	Order Code
TB Joint Unit	270	1004256

▶▶ TB LINE FEED UNITS - CONTINUOUS TYPE

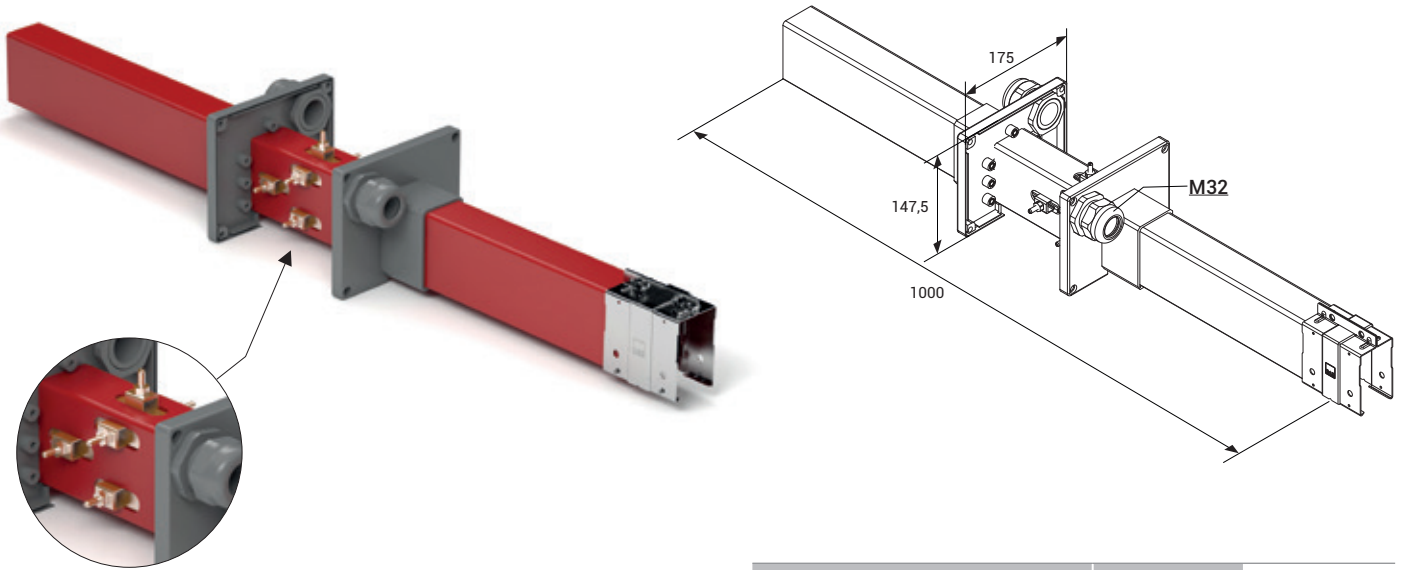

Description	Weight (gr)	Order Code
TB Line Feed Unit - Continuous Type	2750	3025148

Type of the feeding element is selected by calculating the voltage drop and the location of the power supply that shall provide power to the system.

▶▶ TB LINE FEED UNITS - JOINTED TYPE

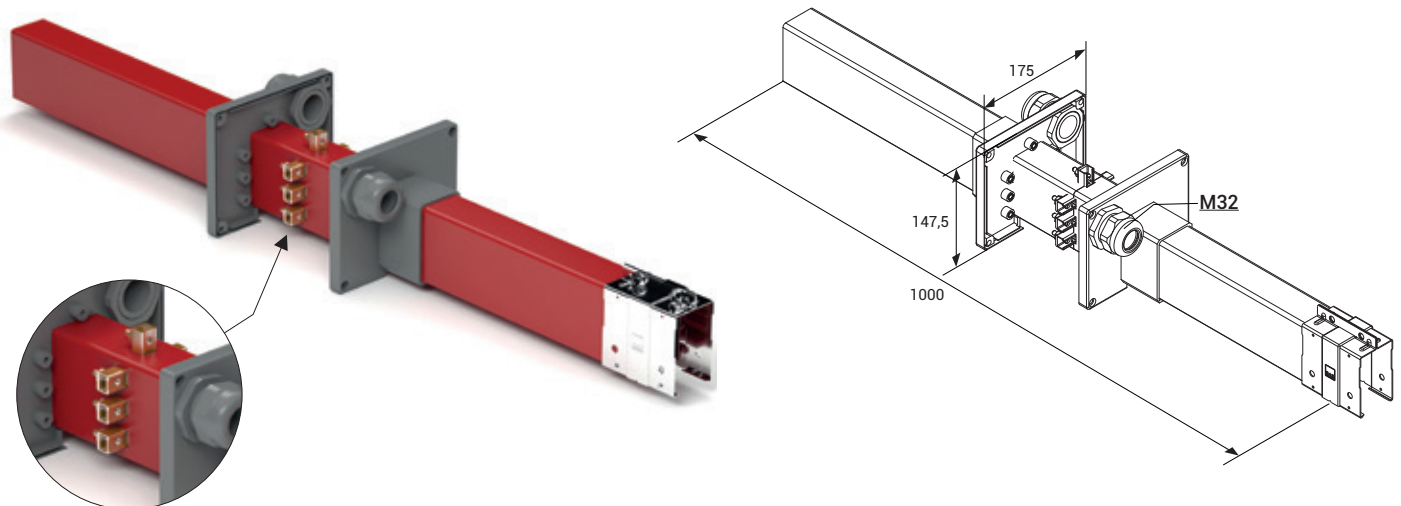

Description	Weight (gr)	Order Code
TB Line Feed Unit - Jointed Type	2850	3025150

Type of the feeding element is selected by calculating the voltage drop and the location of the power supply that shall provide power to the system.

▶▶ **TB REPAIR ZONE UNIT**

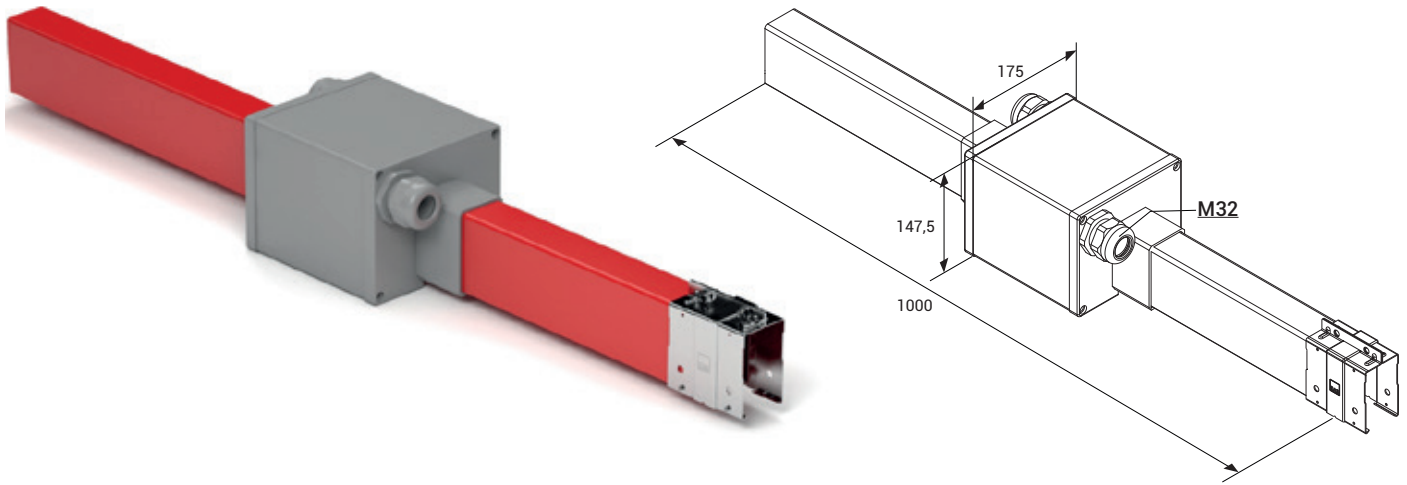

Description	Weight (gr)	Order Code
TB Repair Zone Module	2700	3025003

Current supply shall be cut off when a machine working on the line shall be maintained or repaired. Repair zone module is used to create a currentless area on the busbar so that the other machines operating on the same line may continue to work.

▶▶ **TB CURRENT COLLECTOR REPLACEMENT MODULE**

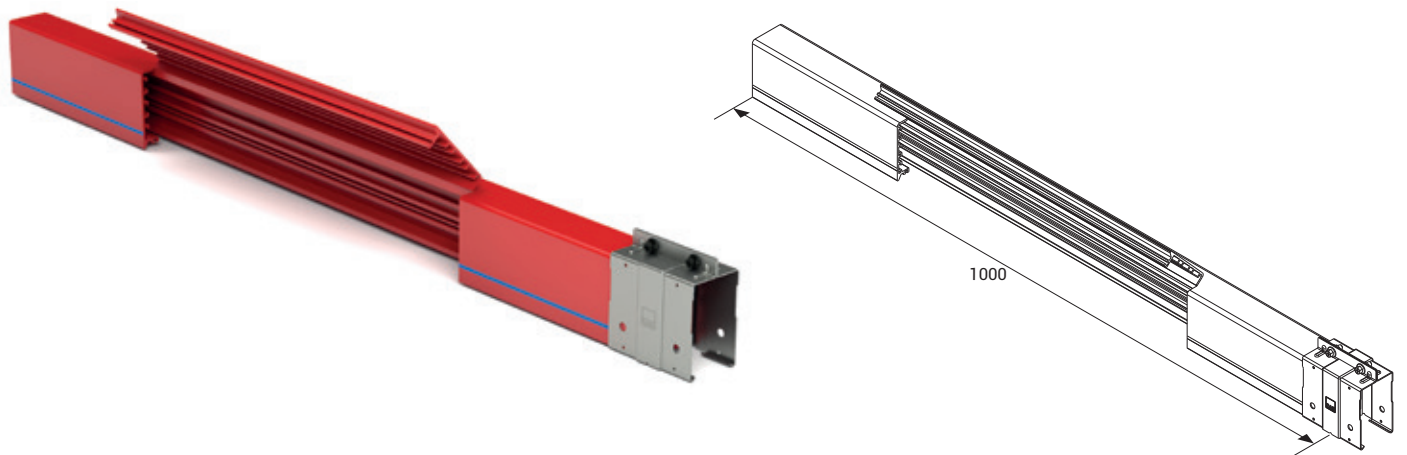

Description	Weight (gr)	Order Code
TB Line Feed Unit - Jointed Type	2250	3024593

This unit is used to remove an existing current collector or to add extra trolleys. The unit is obtained by cutting a 50cm section from the PVC housing.

▶▶ TB CURRENT COLLECTORS WITH CABLE (4P/7P)



Model	Brushes Number-Current (A)	Weight (gr)	Order Code
TB	4P - 35A (Single)	1750	3025145
	4P - 70A (Double)	2900	3024947
	4P - 105A (Triple)	3950	3024945
	7P - 35A/70A (Single)	2200	3025144
	7P - 70A/140A (Double)	3900	3024946
	7P - 105A/210A (Triple)	5650	3024944

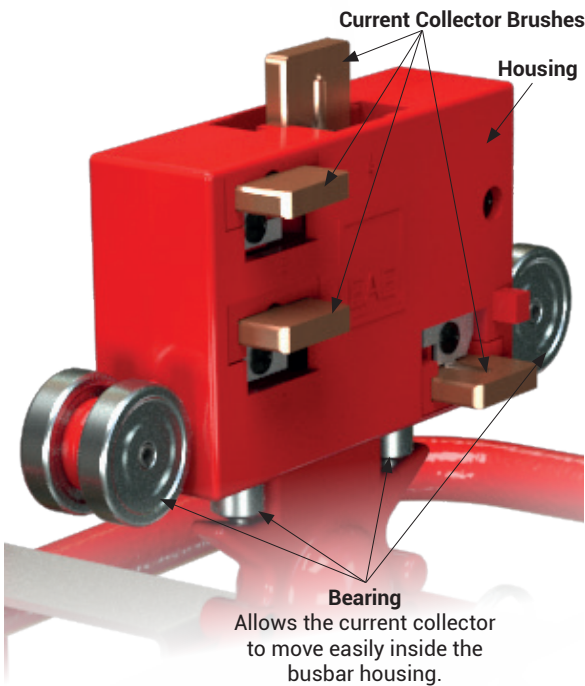
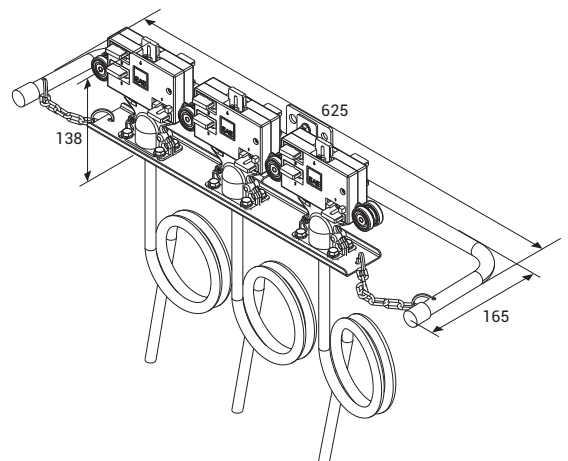
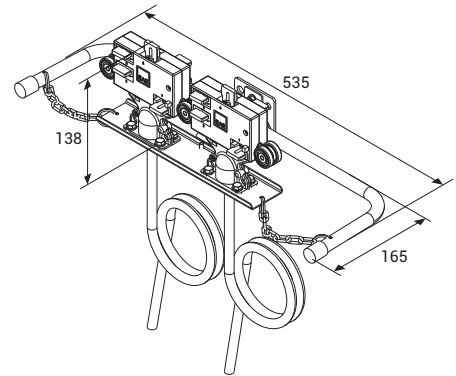
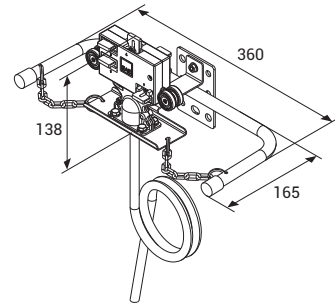

Current collector are the moving elements of the trolley busbar systems. Current collector brushes rub against the conductors and draw continuous current while they move through the busbar line. They adapt to shaky and vibrant conditions thanks to the moving brushes. As current collecting and transfer systems are included in the C-PVC housing, they are protected against human contact.

TB Current collector models operating speed is max. 100m/min.

▶▶ TB CURRENT COLLECTOR WITH WHEEL BRUSHES (4P)

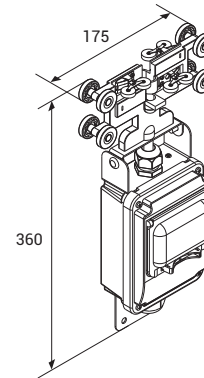
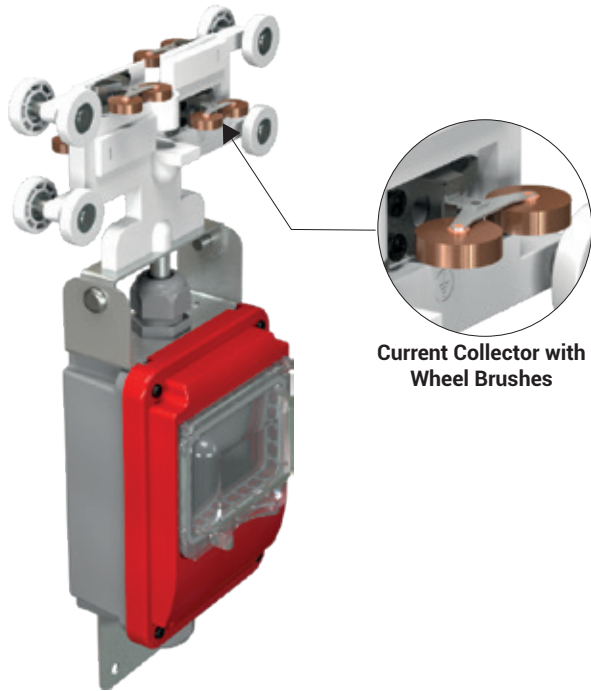

Model	Brushes Number-Current (A)	Weight (gr)	Order Code
TB	4P - 16A	900	3024774

Current collector with Wheel Brush simplify the movement of the current collectors inside the busbar by reducing the time at the tables when movement is provided by the personnel.

▶▶ TB CURRENT COLLECTORS WITH FUSE BOX (5P)

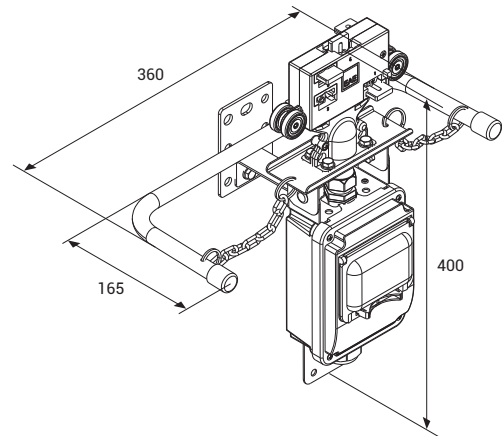
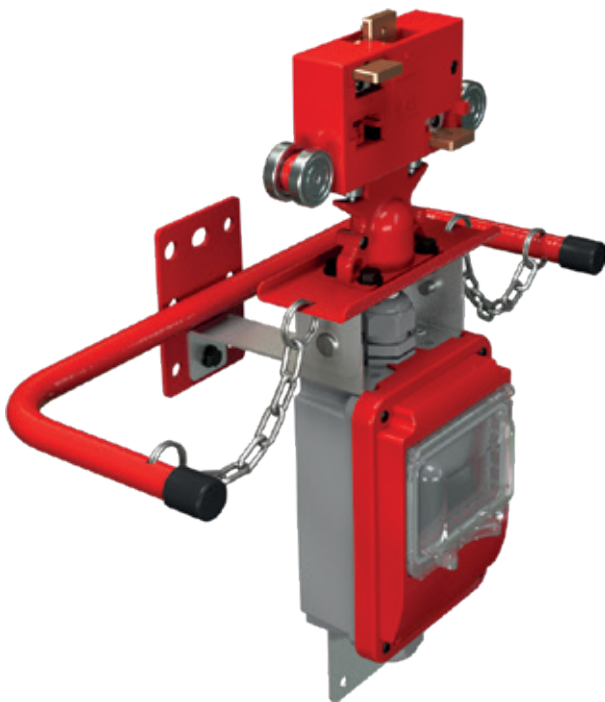

Model	Brushes Number-Current (A)	Weight (gr)	Order Code
TB	5P - 35A	1850	3024403

Fuse boxed with both staff and current receiving area carts current machine's safety can be raised to a higher level. In addition, when it is desired to cut the power of one of the machines on a line, the current is cut off through the fuse, other machines on the line can continue to operate.

▶▶ TB PLASTIC SLIDING HANGER

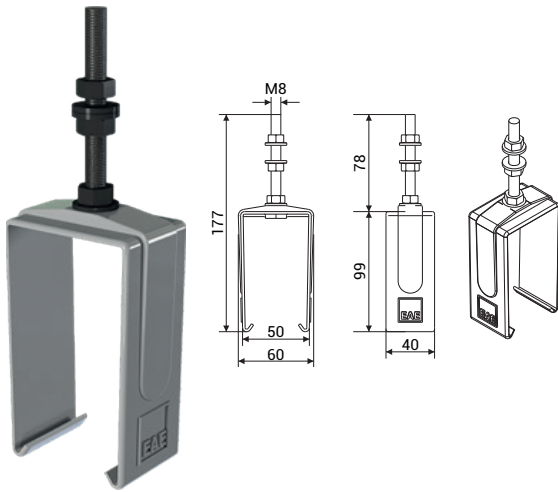

▶▶ TB STEEL SLIDING HANGER

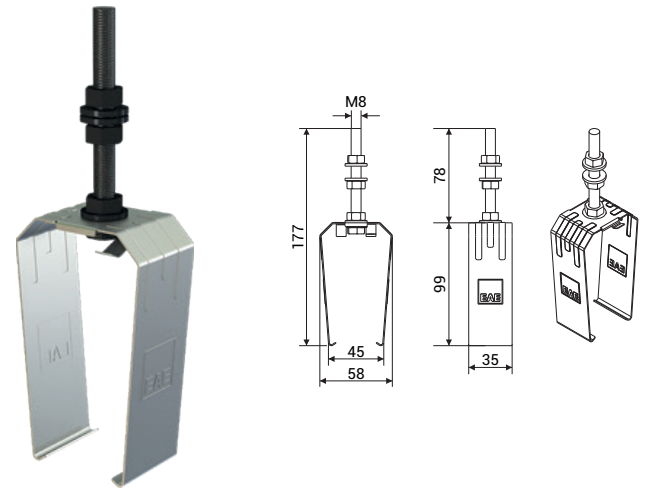

Trolley busbar should be mounted with sliding hangers and each hangers should be between 1,30m - 1,50m. Distance between sliding hanger and other units (joint unit, feeder etc.) should be minimum 300mm.

Description	Weight (gr)	Order Code
TB Plastic Sliding Hanger	85	1004257

Description	Weight (gr)	Order Code
TB Steel Sliding Hanger	100	1006055

▶▶ TB HANGER BRACKET

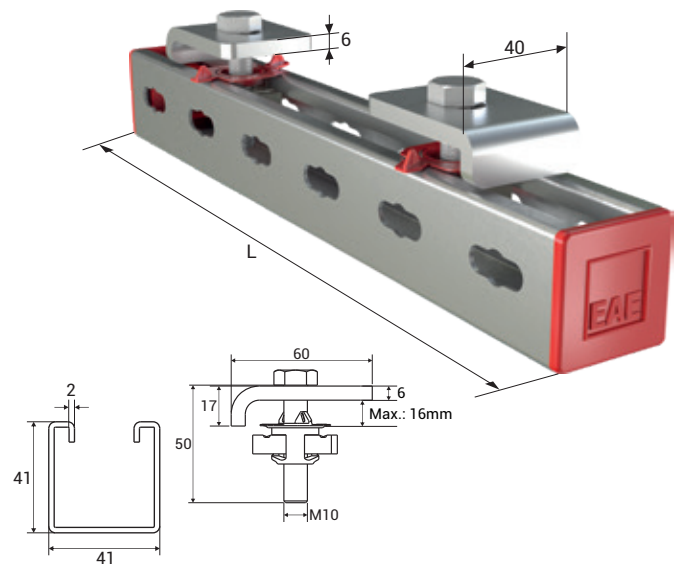
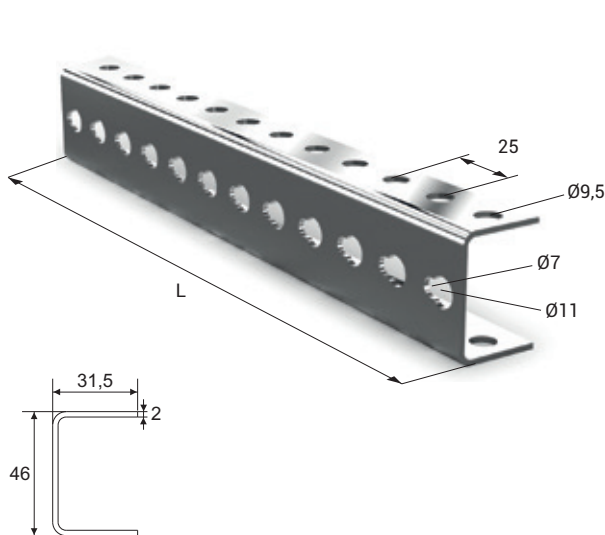

Description	L (mm)	Weight (gr)	Order Code
TB Hanger Bracket	250	350	3025153
URC-C/S Hanger Bracket	500	700	3034560
URC-A Hanger Bracket	750	1050	3025382

Description	L (mm)	Weight (gr)	Order Code
TB BR Hanger Bracket Set	300	800	3178916
URC-C/S BR Hanger Bracket Set	600	1250	3178917
URC-A BR Hanger Bracket Set	800	1550	3178918

▶▶ **TB CURRENT COLLECTOR BRUSHES**



Description	Weight (gr)	Order Code
TB Current Collector Phase Brush	20	2011161

▶▶ **TB COPPER CONDUCTORS**



Description	Order Code
TB 0,80x13,50 (TB Copper)	1004261
TB 1,00x13,50 (TB Copper - 80A)	1004260
TB 1,50x13,00 (TB Copper - 100A)	1004258
TB 2,00x13,00 (TB Copper - 125A)	1004259

▶▶ **TB CONDUCTOR CASSETTE**



Conductor cassette shall be used to prevent damage to the conductors while the copper conductors are installed on the busbar.

Description	Weight (gr)	Order Code
TB Conductor Cassette	6800	3025151

▶▶ **TB CONDUCTOR MOUNTING TOOL**



Description	Weight (gr)	Order Code
TB Conductor Mounting Tool	250	3025143

▶▶ **TB GASKET**



■ Continuous length is maximum 300 meters.

Description	Weight (gr/m)	Order Code
TB Gasket Roll (m)	30	1037761

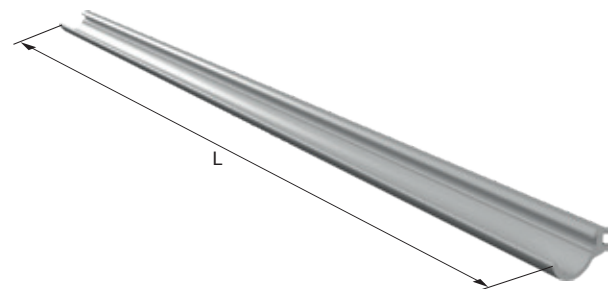

■ Gasket should be ordered twice the line length.

Description	L (mm)	Weight (gr)	Order Code
TB Gasket Straight Length (Pcs.)	4000	120	1037762

►► VOLTAGE DROP

The voltage drop in the busbar lines shall be inspected as per the busbar type selected according to the total current calculated based on the ambient temperature and operating period of the system. Maximum acceptable value for voltage drop is 3%.

For Direct Current

$$\Delta U = 2 \cdot L_t \cdot I_G \cdot R$$

ΔU = Voltage Drop [V]

For Mono-Phase Alternative Current

$$\Delta U = 2 \cdot L_t \cdot I_G \cdot Z$$

I_G = Total current [A]

R = Resistance of the busbar [Ω/m]

For Three-Phase Alternative Current

$$\Delta U = \sqrt{3} \cdot L_t \cdot I_G \cdot Z$$

Z = Impedance of the busbar [Ω/m]

L_t = Calculated Hole Length [m]

Note : Calculation of the current drawn during first start in various motor types;

I_A = Total current drawn in the first start of the motors [A]

For the starting current; Three-phase asynchronous drive in direct start

Slip ring motor

Frequency converter

I_A = I_G x calculated as 5 to 6

I_A = I_G x calculated as 2 to 3

I_A = I_G x 1,20 to 1,50 calculated between.

►► CALCULATION OF FEEDING POINTS

When we take L_t as the length of the line, feeding points may be selected as shown in the diagrams below to keep the L voltage drop at minimum and it may be used as the hole length for the calculation of L_t voltage drop.



1 feeding point from the start, $L_t=L$

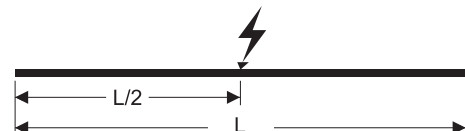

1 feeding point from the center, $L_t=L/2$



2 feeding points from the start points, $L_t=L/4$



2 feeding points, $L_t=L/6$

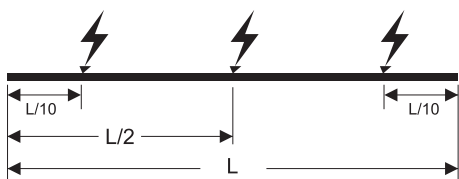

3 feeding points, $L_t=L/10$

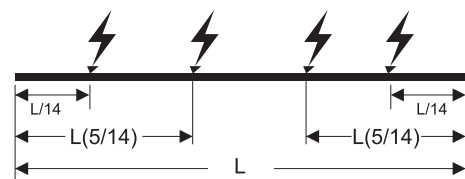

4 feeding points, $L_t=L/14$

►► INSTALLATION MANUAL

TB - INSTALLATION OF JOINT UNIT

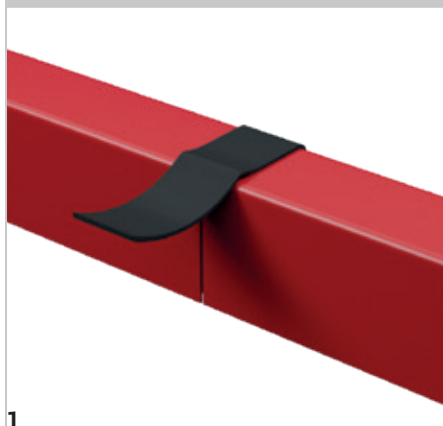

1
The joint point is covered using a self adhesive EPDM gasket.

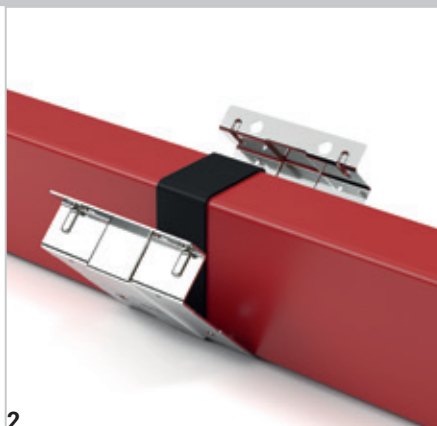

2
Engage the joint unit to the bottom of the busbar and close it.

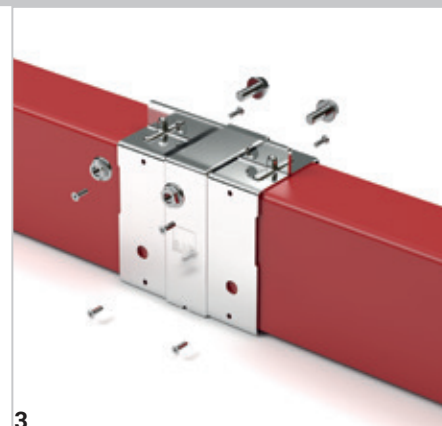

3
Secure it to the housing with screws.

TB - FEEDER UNIT

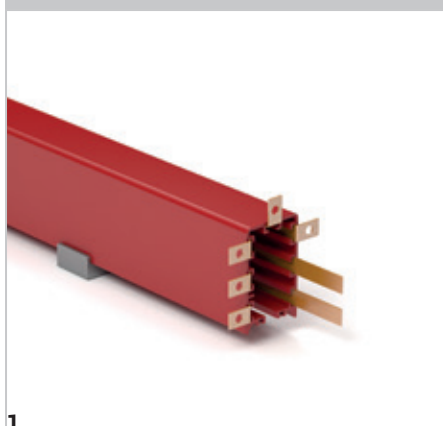

1
Conductors are bend 90° and pushed into the housing.

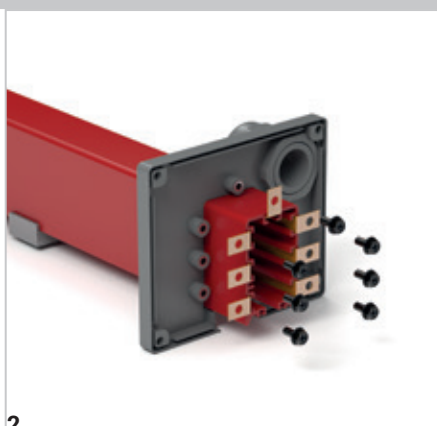

2
Screw the conductors to the feeding module. Connect the feeding cables by putting them through the cable gland.

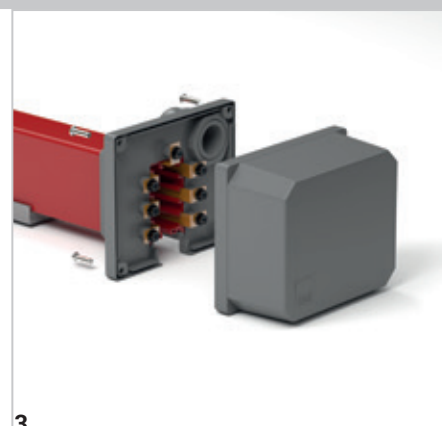

3
Close the module cover and screw it.

TB - LINE FEED UNIT - 2 (JOINTED TYPE)

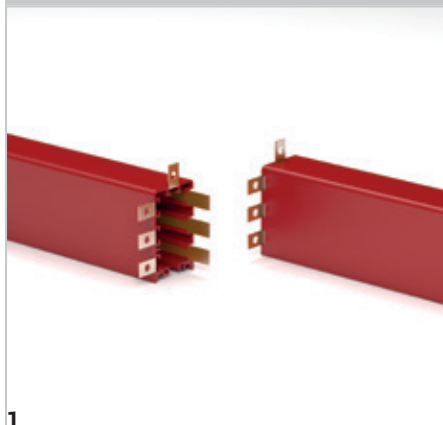

1
Conductors are bend 90° and pushed into the housing.

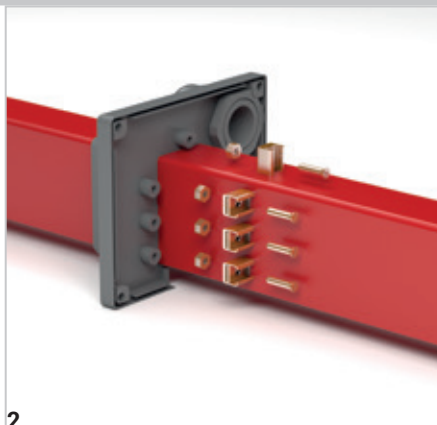

2
Put conductors back-to-back and join them with clips. Connect the feeding cables to the clips.

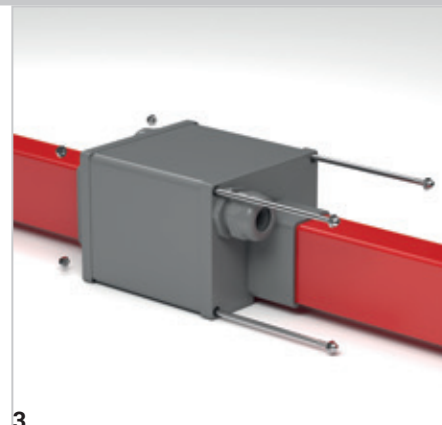

3
Close the module cover and screw it.

►► INSTALLATION MANUAL

TB - LINE FEED UNIT - 1 (Continuous Type)

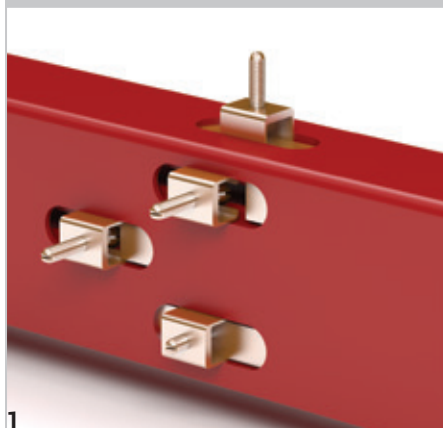

1
Put the conductors through the clips and screw them.

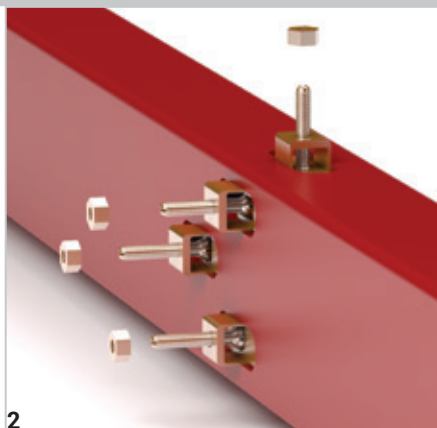

2
Connect the feeding cables to the clips with nuts.

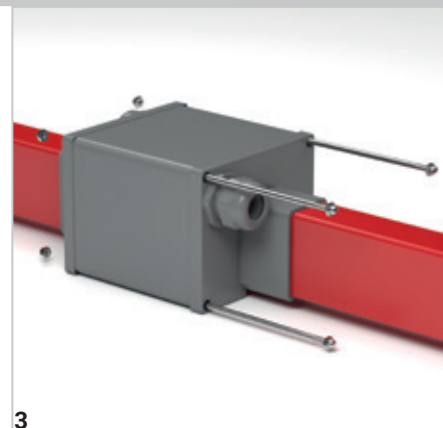

3
Close the module cover and screw it.

TB - END CLOSURE

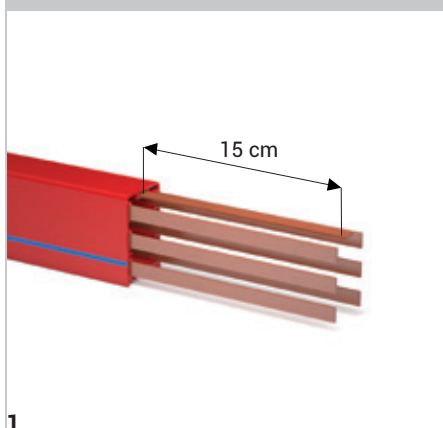

1
Cut the coppers at the end of the line by leaving an extra length of 15 cm.

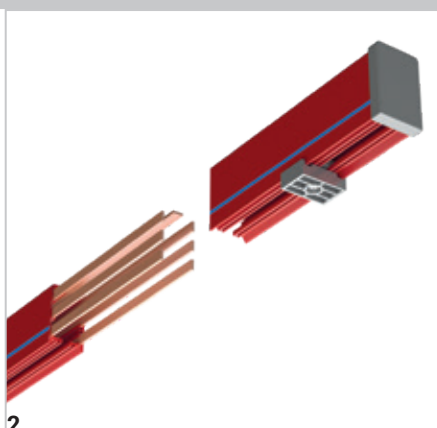

2
After placing the current collector to the system, place the End Closure so that it shall house the coppers.

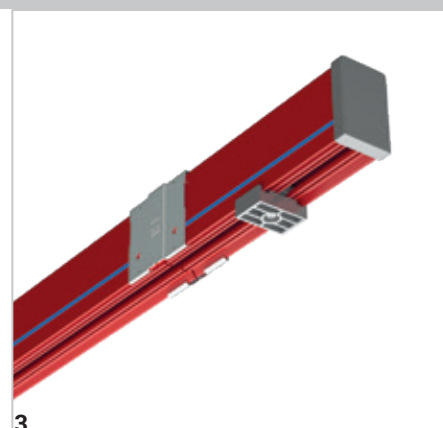

3
Install it on the system as you do while installing the extension.

TB - CONDUCTOR MOUNTING TOOL

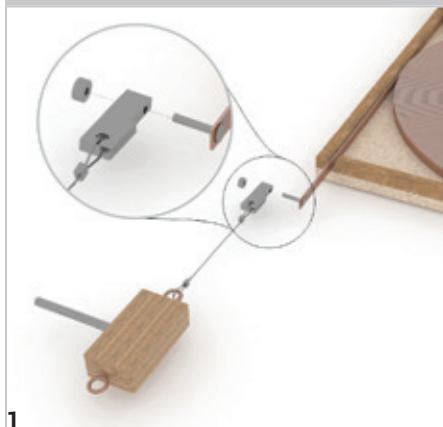

1
Screw the conductor to the conductor mounting tool.

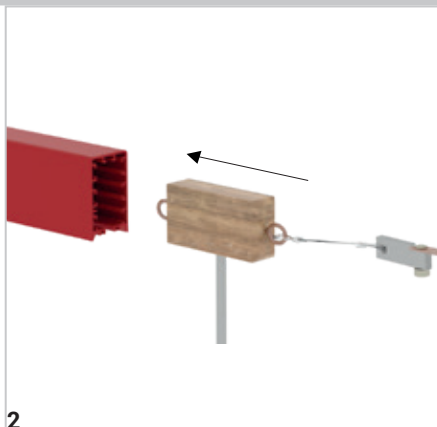

2
Drive the conductor mounting tool along the line.

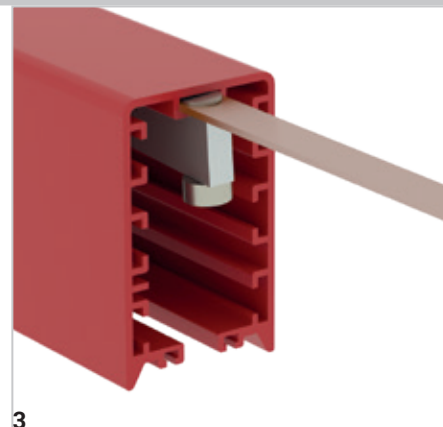

3
Ensure that the conductor is seated.

►► OFFER REQUEST FORM

Date :

Project Name	:	<input type="text"/>
Company	:	<input type="text"/>
Name Surname	:	<input type="text"/>
Tel	:	<input type="text"/>
E-Mail	:	<input type="text"/>
Address	:	<input type="text"/>

General Data

Track Length	:	<input type="text"/>
Number of Cranes on Track	:	<input type="text"/>
Crane Travel Speed	:	<input type="text"/>

Environmental Data

Operating Environment	:	<input type="checkbox"/> Indoor	<input type="checkbox"/> Outdoor
Ambient Temperature	:	<input type="text"/> °C min.	<input type="text"/> °C max.
Other Operating Conditions (Humidity, Dust, Chemical Influence, etc.)	:	<input type="text"/>	

Electrical Data

Operating Voltage	:	<input type="text"/> Volts	<input type="checkbox"/> AC	<input type="checkbox"/> DC			
		<input type="text"/> Phases	<input type="checkbox"/> N	<input type="checkbox"/> PE			
Position and Number of Feeder	:	<input type="text"/> from End	<input type="text"/> from Middle				
Duty Cycle (%)	:	<input type="checkbox"/> 50%	<input type="checkbox"/> 60%	<input type="checkbox"/> 70%	<input type="checkbox"/> 80%	<input type="checkbox"/> 90%	<input type="checkbox"/> 100%

Motor Specifications	Crane - 1		Crane - 2		Crane - 3	
	Power (kW)	Current (A)	Power (kW)	Current (A)	Power (kW)	Current (A)
Hoist motors	<input type="text"/>	<input type="text"/>	<input type="text"/>	<input type="text"/>	<input type="text"/>	<input type="text"/>
Auxiliary motor	<input type="text"/>	<input type="text"/>	<input type="text"/>	<input type="text"/>	<input type="text"/>	<input type="text"/>
Long travel	<input type="text"/>	<input type="text"/>	<input type="text"/>	<input type="text"/>	<input type="text"/>	<input type="text"/>
Cross travel	<input type="text"/>	<input type="text"/>	<input type="text"/>	<input type="text"/>	<input type="text"/>	<input type="text"/>

Options

Brackets Required	:	<input type="checkbox"/> Yes	<input type="checkbox"/> No
Repair Zone Required	:	<input type="checkbox"/> Yes	<input type="checkbox"/> No
		<input type="text"/> Qty	
Collector Replacement Required:		<input type="checkbox"/> Yes	<input type="checkbox"/> No
		<input type="text"/> Qty	

Descriptions	:	<input type="text"/>
--------------	---	----------------------

►► Declaration

CE DECLARATION OF CONFORMITY

Product Group E-Line TB Trolley Busbar Systems
Manufacturer Akcaburgaz Mahallesi, 3114. Sokak,
No:10 34522 Esenyurt-Istanbul

The objects of the declaration described below is in conformity with the relevant Cable gland harmonisation legislation. This declaration of conformity is issued under the sole responsibility of the manufacturer.

Standard:**TS EN 61439-6**

Low-voltage switchgear and controlgear assemblies - Part 6: Busbar trunking systems

CE - Directive:

2014/35/EU "The Low Voltage Directive"

2014/30/EU "(EMC) Electromagnetic Compatibility Directive"

2011/65/EU "RoHS Directive"

Technical Document Preparation Official:

EAE Elektrik Asansor End. Insaat San. Tic. A.S.
Akcaburgaz Mahallesi, 3114. Sokak, No:10 34522 Esenyurt-Istanbul

Emre GÜRLEYEN

Date

20.04.2016

Document Authorized Signatory

Elif Gamze KAYA OK
Deputy General Manager



PRODUCT TYPES



BUSBAR ENERGY DISTRIBUTION SYSTEMS



CABLE TRAYS



TROLLEY BUSBAR ENERGY DISTRIBUTION SYSTEMS



INDOOR SOLUTIONS



SUPPORT SYSTEMS



EAE Elektrik A.S.
Head Office
Akcaburgaz Mahallesi,
3114. Sokak, No:10 34522
Esenyurt - Istanbul - TURKEY
Tel: +90 (212) 866 20 00
Fax: +90 (212) 886 24 20

EAE DL 3 Factory
Busbar
Gebze IV Istanbul Makine ve
Sanayicileri
Organize Bolgesi, 6. Cadde,
No: 6 41455 Demirciler Koyu,
Dilovası - Kocaeli - TURKEY
Tel: +90 (262) 999 05 55
Fax: +90 (262) 502 05 69

Please visit our website for the updated version of our catalogues.
www.eaeelectric.com



IEC 61439-6



Catalogue 08-Eng. / Rev 09 / 500 pcs. 02/09/2022
S.S.

EAE has full right to make any revisions or changes on this catalogue without any prior notice.