

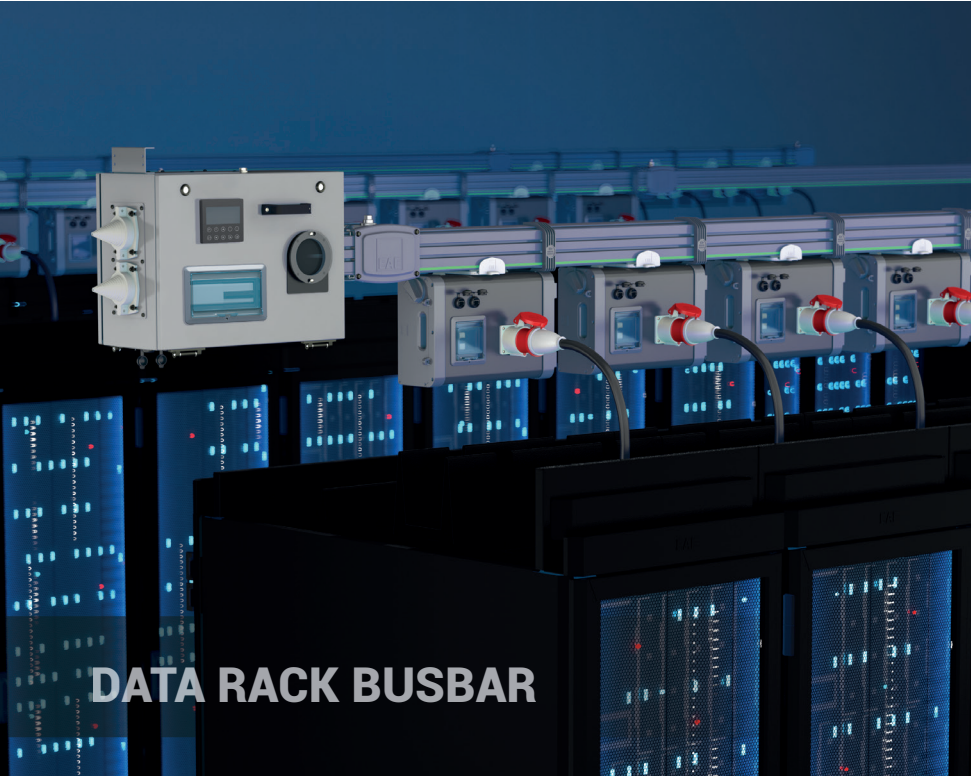

E-LINEKD

MANUAL



DATA RACK BUSBAR

E-LINEKD



CONTENTS

Introduction.....	2
General.....	3
Unloading, Handling and Storage of Products.....	4
Handling and Storage.....	5
Handling and Lifting.....	6
Handling and Hanging.....	7
Joint Structure.....	8
Energizing.....	9
Order Code System.....	10
Overview.....	11-12
Joint Installation.....	13
Tap-Off Box Installation.....	14
Tap-Off Box Horizontal Installation.....	15
Fixing Elements, Application I - Application II.....	16
Fixing Elements, Application III.....	17
Fixing Elements, Ceiling Mounting Fittings - Tray Support -.....	18
Connection Accessories	
Equipment Used.....	19
Measuring a Special Length.....	20
Busbar Installation Applications.....	21
Certificates.....	22
Declaration.....	23
EAE Electrical Test Report.....	24-25
Product Overview.....	26-27

Dear Customer

EAE Elektrik A.S. Products are designed to provide the maximum benefit in efficiency and service. Our products are manufactured in accordance with IEC standards and EAE is quality assured to ISO 9001 standards in their modern production plants in Istanbul .

The components that you have purchased are manufactured by a completely environment conscious, that is ISO 14001 certified.

These instructions should be read carefully and acted upon before taking delivery of equipment on site.

Handling, installation and operation of busbar systems should be carried out only by skilled, trained and authorized personnel using all associated equipment such as rubber gloves, helmet, safety glasses or face shields and flash resistant clothing in accordance with established safety practices.

The busbar system's successful operation depends on correct handling, installation, operation and maintenance. Improper installation may cause personal injury and the failure of the busbar system and damage to other property.



**BUSBARS SHOULD
NOT BE IN TOUCH WITH
ANY LIQUID MATERIAL**

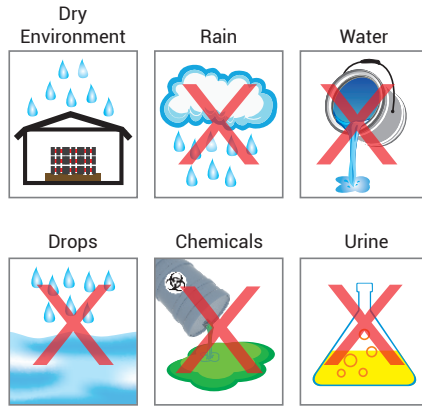

**BUSBARS THAT ARE NOT
ASSEMBLED COMPLETELY
HAVE NO PROTECTION
AGAINST TO WATER.**



Unloading:

- Forklift is the most reliable and easiest method for the unloading of the products from the container or the truck arriving at the worksite.
- Utmost care is required to be exercised to ensure avoidance of any harm that can be sustained by the products during the unloading process.

Storage:

- From the packing list check the number of pallets received, the number, dimensions and the condition of the busbar lengths. Advise any discrepancies immediately to the local EAE representative.
- All products should be stored in a dry environment.

Handling:

- Do not handle the materials using steel ropes or hooks. As shown in the busbar should be lifted using lifting straps placed at each end of the busbar length.
- Short modules may be lifted using a single strap providing that the piece is balanced.
- A wooden spacer should be used every 1.5m when storing the lengths placed on top of each other.
- Do not stack more than 5 modules on each other horizontally.

► Joint Area General Information

Controlling of Juncture Area:

- The final check form supplied should be completed for each busbar joint installed.
- Perform a megger test after each joint, and ensure that there is no problem on the joint area.
- In order to prevent damage to the terminals and transformers during this test, remove their connections or protect them.
- After every electrical test, the system must be discharged to earth.
- After completing all electrical tests, make the terminal, MCCB and fuse connections again.
- The form filled in after each test should be submitted to the EAE representative. The product quality approval form (186) should be completed and submitted to us to validate the warranty.

1- General guidelines are given to protect the busbar straight lengths and modules and reduce the risk of personal injury and equipment damage during handling on site.

2- As soon as the container or truck arrives on site, a suitable forklift is required for easy and convenient unloading from vehicle directly to the ground level.

3- All pallets should be checked by unpacking them sufficiently to inspect them for possible transit damage and to determine that the shipment is complete and correct as per Packing List provided.

* If any of the items is missing from the Packing List or any piece is damaged during transportation, Insurance Company must be informed immediately for proper reporting with all required documents for further action.

4- All busbar straight lengths and modules should be handled with care to avoid damage to internal components and the twisting of housing or its finish.

5- When the lengths and modules are required to be taken from the pallets to the erection area, those should be hoisted using metal rods or bars passed through the 2 sets of holes at each end of the housing body by ensuring the load is stable and safely secured. Then adequate sling and slinging method can be used for shifting from one place to another.

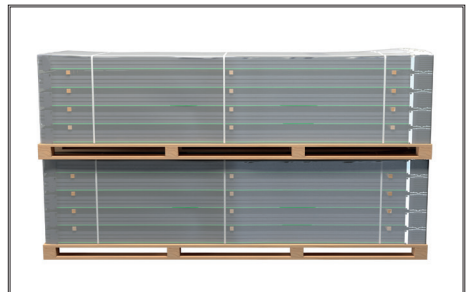
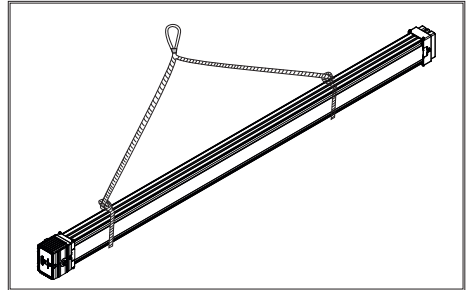

Strapping type ropes should only be used instead of round ropes to prevent the materials slipping during handling.

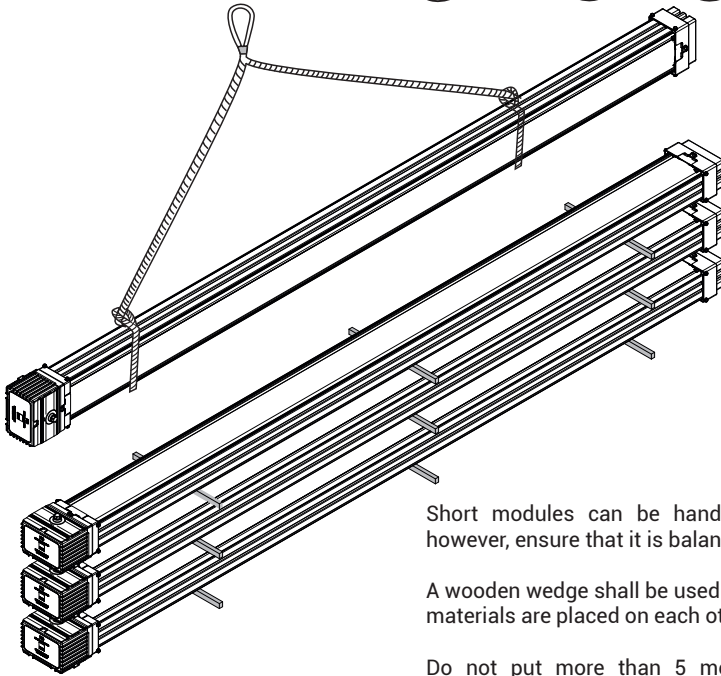
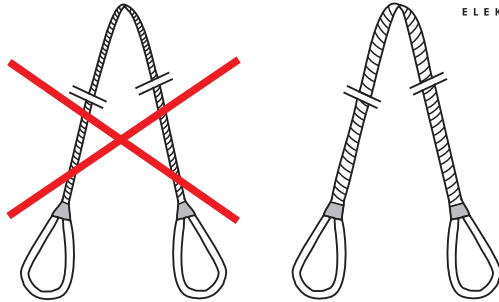

Short modules can be handled by a single rope, however, ensure that it is balanced.

A wooden wedge shall be used every 1.5 m when the materials are placed on each other while storing them.

Do not put more than 5 modules on each other horizontally.

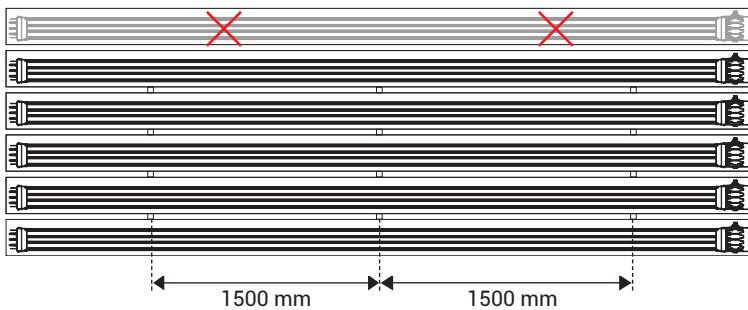

Introduction:

This installation manual includes the details of safe and quick handling and installation of busbar product. It shall be read carefully before starting the procedures on the product and relevant steps shall be followed.

Things To Do:

1. Read the info note on the pallet; lift and handle the the product as shown below taking the pallet weight into consideration.
2. Product shall be hanged and lifted as shown in below while it is handled.
3. Busbar route shall be marked before starting the installation.
4. Installation shall start from a single point (preferably panel) and shall be completed with the last module.

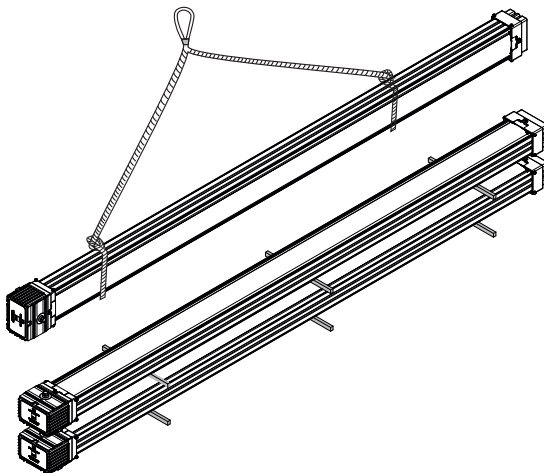

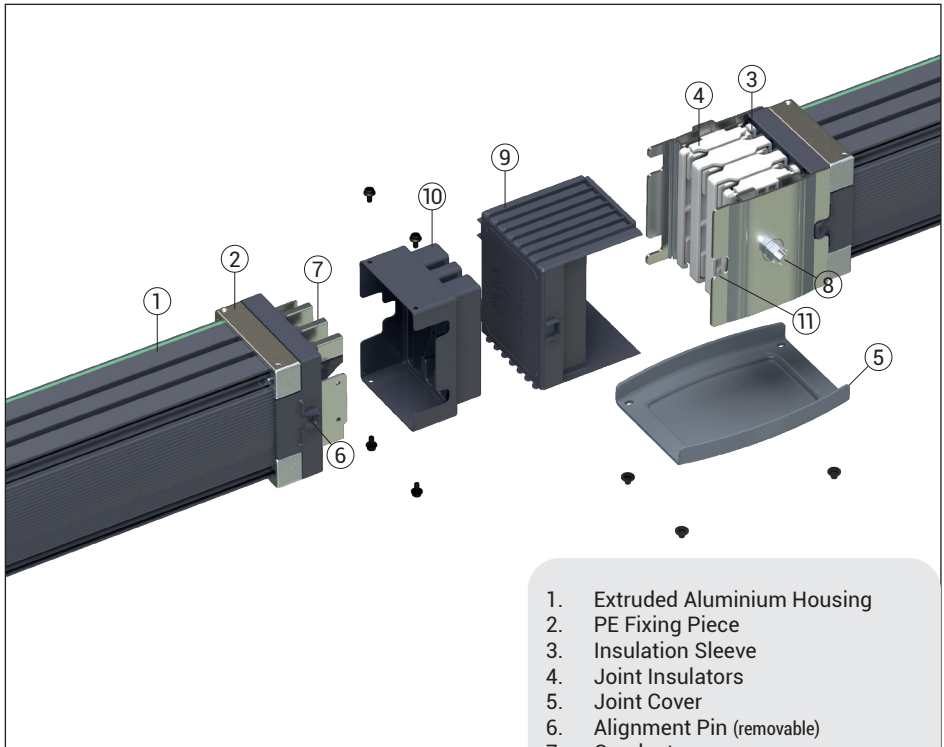

1. Extruded Aluminium Housing
2. PE Fixing Piece
3. Insulation Sleeve
4. Joint Insulators
5. Joint Cover
6. Alignment Pin (removable)
7. Conductors
8. Nut Locking Piece
9. Cover plates
10. Cover plates
11. Alignment Pin Slot

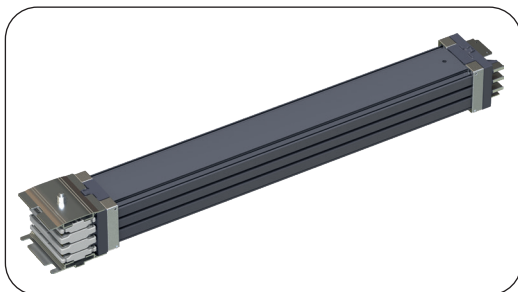

Before Energizing

1-All busbar ratings, routings and supporting systems should be checked as per final isometric drawings.

2-All busbar system should be checked visually to be certain that they are clean and secure. Loose and/or contaminated connections increase electrical resistance which can cause overheating.

3-Any type of blower or compressed air should not be used to avoid blowing dust into busbar joints, tap off boxes or circuit breakers. If there is accumulation of dust and dirt, clean it off by using a soft brush, vacuum cleaner, or clean lint free rags.

4-All joints should be correctly tightened according to the torque value given and should be marked. Then install the locking plates correctly.

5-All Tap Off boxes fed from the busbar should be on "OFF" position.

6-The busbar runs should be isolated by disconnecting all connection

7-Insulation resistance test with an insulation resistance test equipment rated 1000V DC should be conducted to verify the integrity of the system. This test should be performed between phases, neutral and earth. Permanent records should be kept of resistance readings. If the insulation reading appears to be lower than 1 megaohm, then the cause should be investigated.

8-The system phase sequence should be checked in order to match the busbar phases sequence before reconnecting all connections to transformers, switchboards, meters, etc.

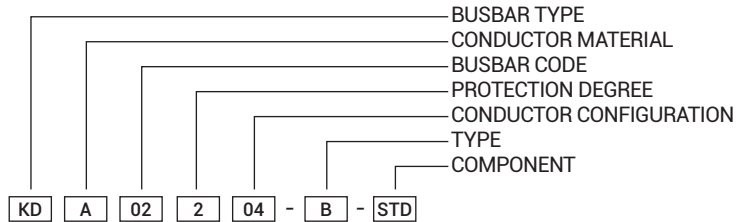

Busbar Type

Aluminium (Al)	A
Copper (Cu)	C

Al Conductor		Cu Conductor	
Rated Current	Busbar Code	Rated Current	Busbar Code
160	01	-	-
250	02	250	02
400	04	400	04
630	06	630	06
800	08	800	08
-	-	1000	10

IP23D

Standard Length	STD
Special Length	X
Feeder Box	B10
Feeder Box	B11
End Closer	S
Left Elbow	L
Right Elbow	R
Central Feeder	TO
Left Side Feeder	TYL
Right Side Feeder	TYR

Type	
Painted	B

Conductor Configuration								
Conductors	Code	L1	L2	L3	N1	N2	CPE	PE (Housing)
4 Conductors	04	✓	✓	✓	✓	-	-	✓
5 Conductors	05	✓	✓	✓	✓	-	✓	✓
6 Conductors	06	✓	✓	✓	✓	✓	✓	✓

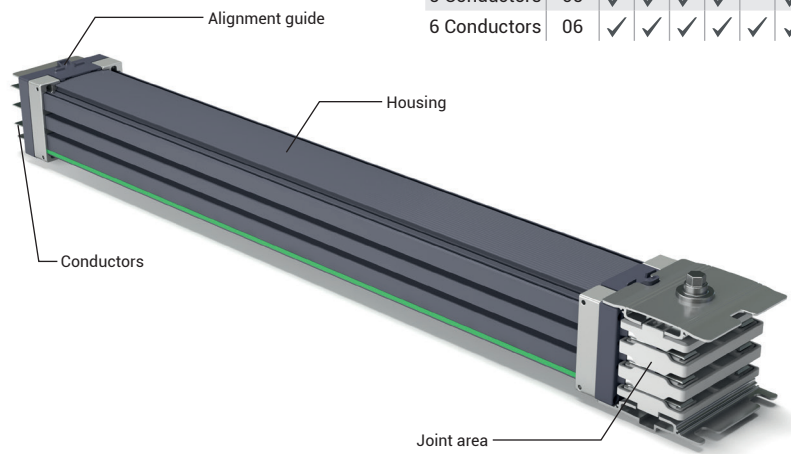

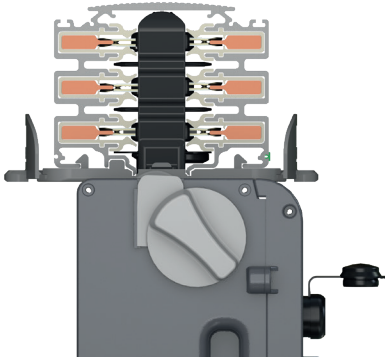

Plug-n-Play

Easy plug-in Tap-Off Boxes on any point along the busbar, remove and relocate wherever necessary

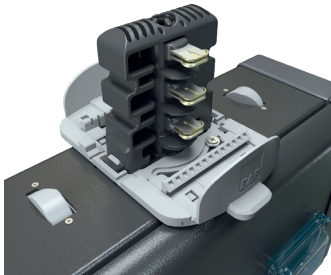

Tap-Off Contacts

Constant contact pressure with double sided spring system and safe locking mechanism on Tap-Off Box contacts

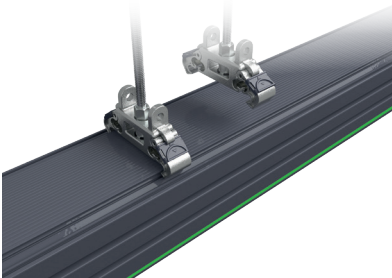

Snap-In Suspension Mechanism

Easy and fast structural mounting thanks to Snap-In Fixing Unit

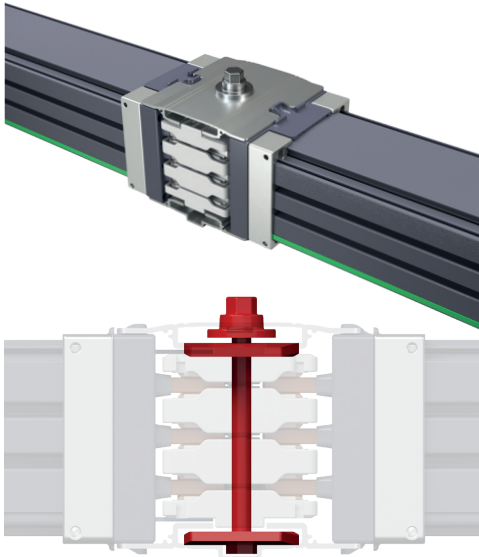

Joint Mechanism

Safe alignment mechanism with a single bolt monoblock joint for correct installation and operation

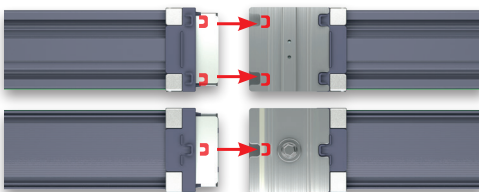

Easy and Safe Installation

Patented EAE Alignment Solution, ideal alignment of the block joint element and busbar thanks to the alignment guides on the joint area



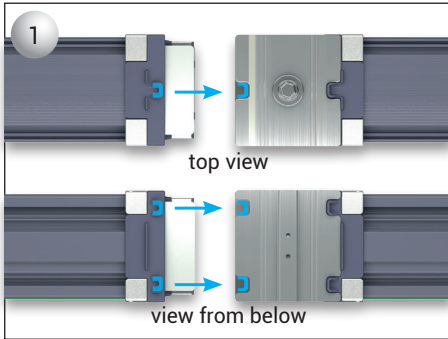

Align the busbars those with and without block joints facing each other and insert together

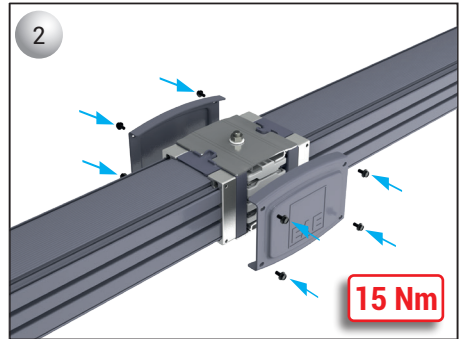

Assemble the joint cover and tighten the cover bolts

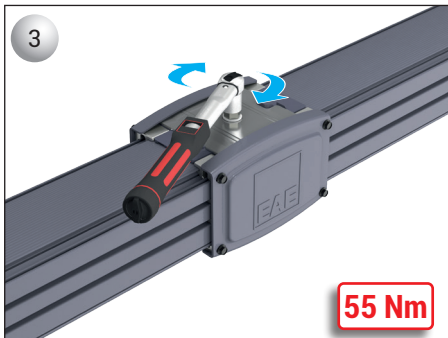

Adjust the torque wrench to 55 Nm and tighten the joint nut

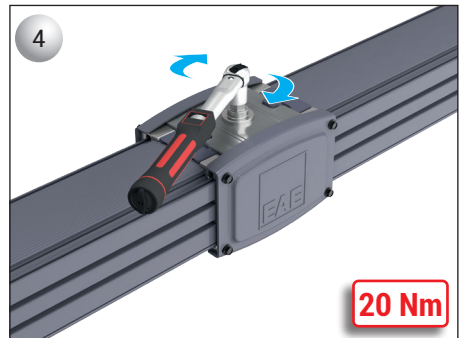

Mount the nut locking piece on the nut

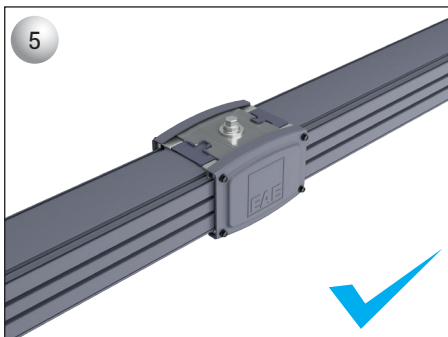

Assembly completed.

KD MANUAL

- ▶▶ Installation
- ▶ Tap-Off Box Installation

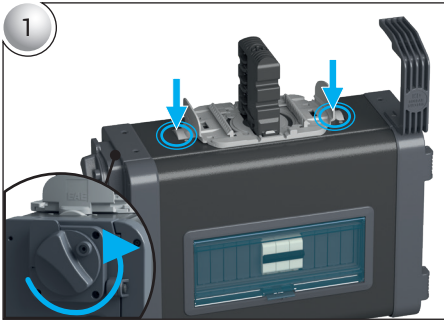

Ensure that the locking latch is in the correct position (as indicated). Engage the installation mechanism by pressing the claws. **If this step is not performed correctly, the tap-off box contact set may be damaged due to excessive mechanical force**

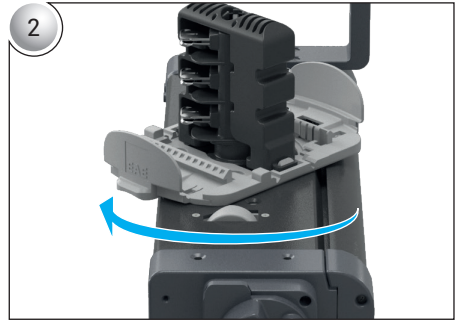

Rotate the contact holder assembly in the indicated direction until it is properly aligned and fully engaged with the base mechanism. Ensure smooth movement and correct alignment with the mounting interface.



Apply a thin, uniform layer of the specified electrical contact lubricant to the designated contact surfaces. This reduces friction, minimizes wear, and ensures reliable electrical conductivity. Lubricate only the specified contact areas.

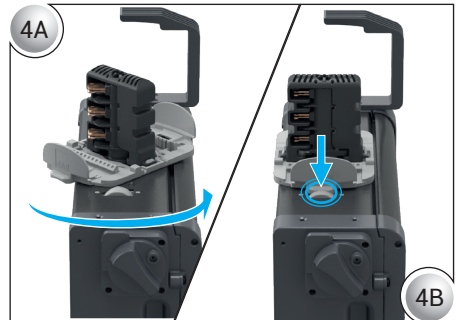

Rotate the contact assembly in the indicated direction until it reaches its final seated position on the base. Press down to engage and secure the locking mechanism (center fixing point as shown) to firmly lock the contact assembly in place. Verify that the assembly is fully seated and properly locked before operation

- Please note that environmental factors such as the amount of lubricant used during production, ambient temperature, humidity, and dust may affect the service life of the TOB conductors. Therefore, it is recommended to reapply lubrication three months after the date of production. In addition, due to the volatility of the lubricant, the lubrication procedure should be repeated whenever there is any doubt regarding its condition.
- The use of high-performance lubricants, such as grease or equivalent products, is strongly recommended. For brand recommendations, please contact us.

Notes: For the purpose of ensuring earth continuity, the installation of the upper mechanism onto the busbar may cause minor paint imperfections on the top part of the box. These imperfections are solely cosmetic and do not affect the electrical or mechanical performance of the product.

KD MANUAL

- ▶▶ Installation
- ▶ Tap-Off Box Installation

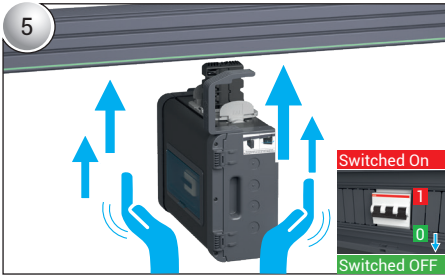

Insert the tap-off box into the busbar slot, ensuring that the mounting angle is aligned with the housing and the green reference line is visible on the side. During installation and removal of the tap-off box, all circuit breakers within the unit shall be in the OFF position. Before the installation, verify that all circuit breakers are switched OFF.

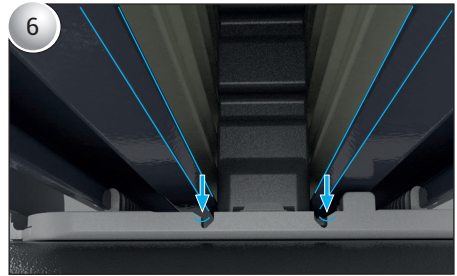

Ensure that the marked guide slots are fully and correctly seated within the busbar channel. Proper alignment is required before proceeding.

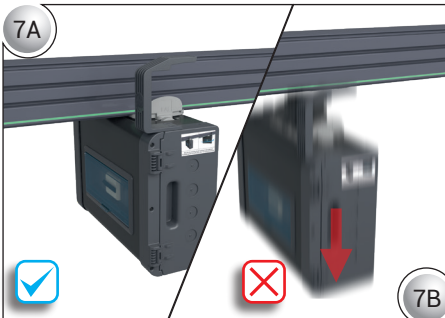

Verify that the tap-off box is fully inserted into the busbar slot and mechanically locked in position.

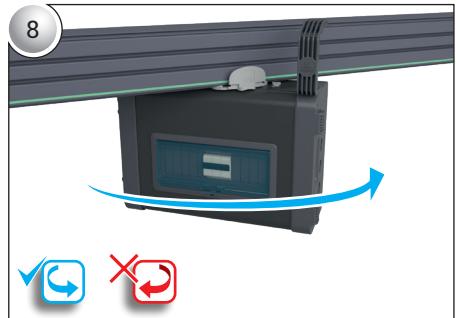

Engage the tap-off box by rotating it in the direction indicated by the arrow until it reaches the operating position. Do not rotate the tap-off box in the opposite direction.

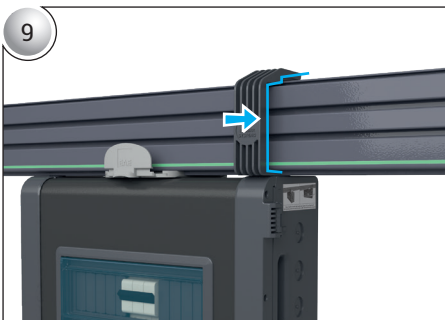

Ensure that the mounting angle is correctly secured onto the busbar housing and properly aligned with the reference line.

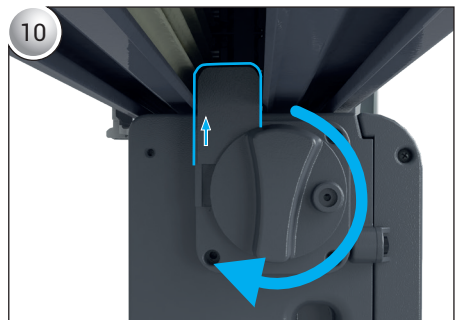

Secure the tap-off box by turning the locking latch in the direction indicated by the arrow until it is fully locked.

Notes: For the purpose of ensuring earth continuity, the installation of the upper mechanism onto the busbar may cause minor paint imperfections on the top part of the box. These imperfections are solely cosmetic and do not affect the electrical or mechanical performance of the product.

KD MANUAL

- ▶▶ Installation
- ▶ Tap-Off Box Horizontal Installation

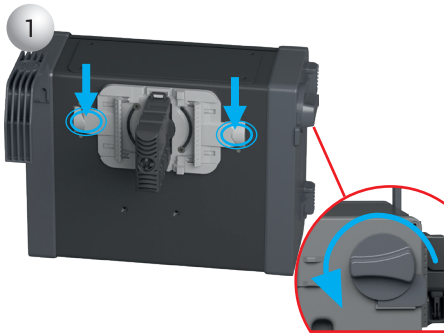

Ensure that the locking latch position is set right (as indicated), setup the installation mechanism by pressing on the claws

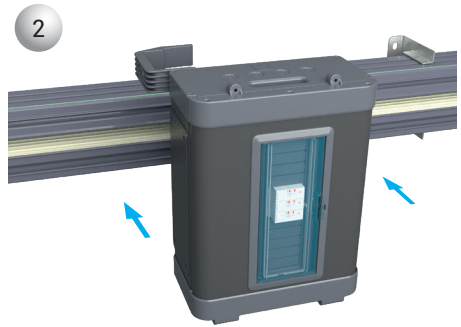

Insert the box inside the slot of the busbar by facing the mounting angle, the box label and the housing 'green' reference line on the same side. **Do not install or remove Plug-in units under load. Make sure breakers are in the off position**

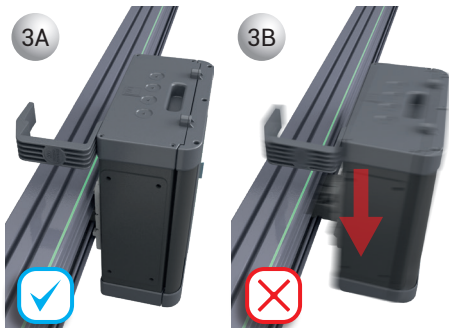

Assure that the box is inserted and locked inside the busbar slot

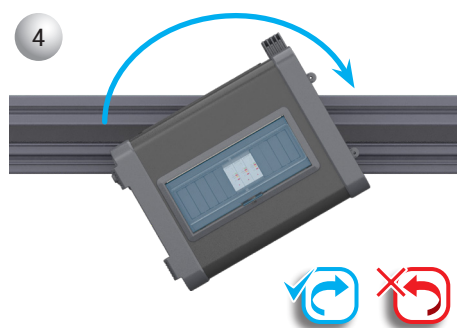

Engage the top off box by rotating in the direction of the arrow. **Do not rotate the box against the direction of the arrow**



Ensure that the mounting angle is correctly attached on the busbar housing



Secure the box by turning the locking latch in direction of the arrow.

Notes: For the purpose of ensuring earth continuity, the installation of the upper mechanism onto the busbar may cause minor paint imperfections on the top part of the box. These imperfections are solely cosmetic and do not affect the electrical or mechanical performance of the product.

► Application I : Threaded Rod with Snap-In Fixing Unit

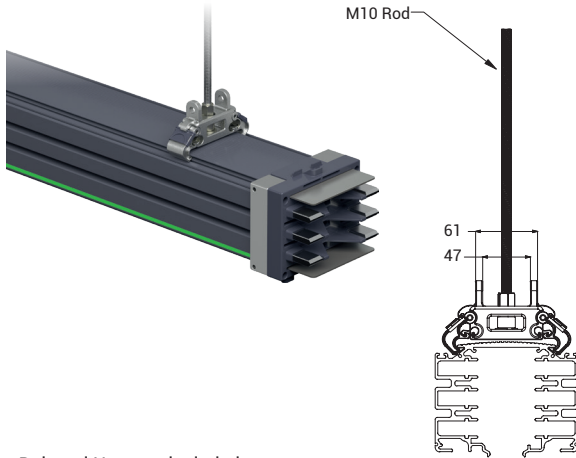

THREADED ROD SUPPORT

KD SNAP-IN	2143683
------------	---------

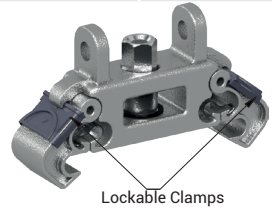

► Fixing Unit Uninstallation

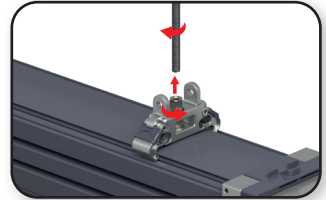

* Bolt and Nuts are included.

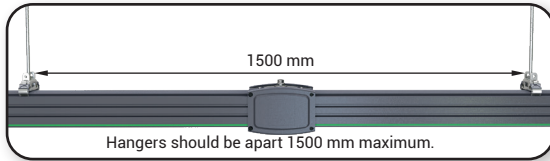

* The minimum engagement into the hanger is 20 mm.

► Application II : TMP Ceiling Support with Snap-In Fixing Unit

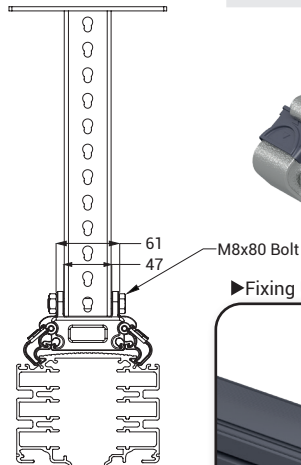
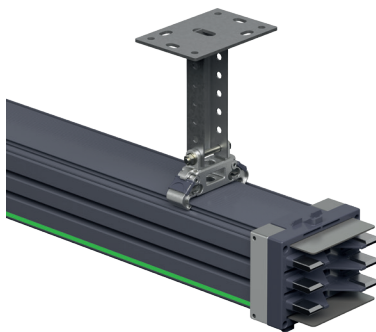

TMP CEILING SUPPORT

KD SNAP-IN	2143682
------------	---------

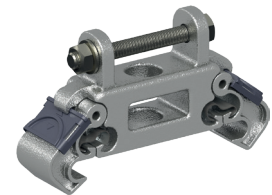

► Fixing Unit Uninstallation

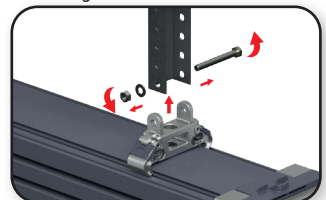

* Bolt and Nuts are included.
* All dimensions in mm.

► Application III : TMP Ceiling Support and Tray Bracket with Snap-In Fixing Unit

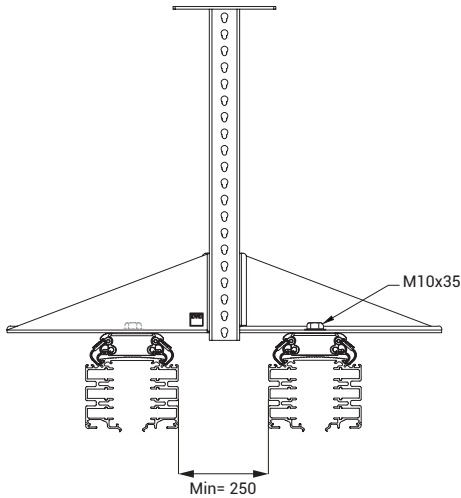
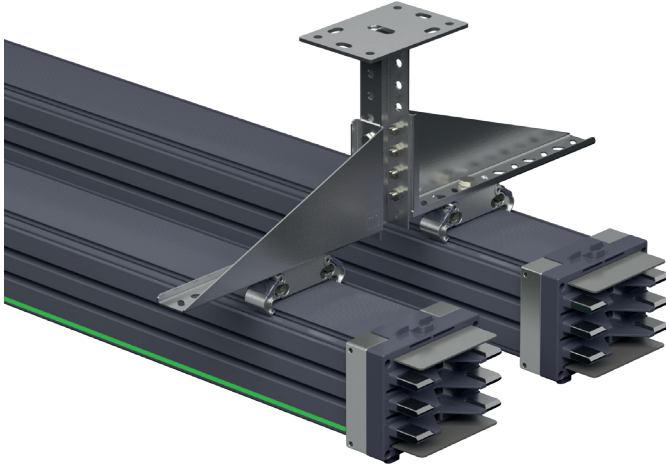

TS TRAY SUPPORT

KD SNAP-IN

2143684

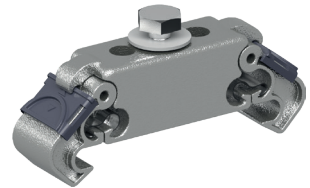

► Fixing Unit Uninstallation

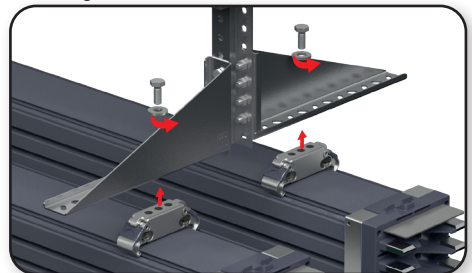

- * Bolt and Nuts are included.
- * All dimensions in mm.

► Ceiling Mounting Fittings

Hot Dip Galvanized After Fabrication (TS EN ISO 1461)

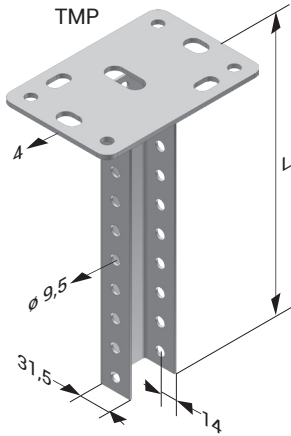

► Tray Supports

Hot Dip Galvanized After Fabrication (TS EN ISO 1461)

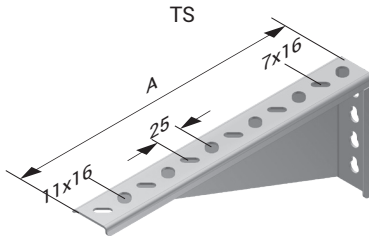

► Connection Accessories

M10 Rod

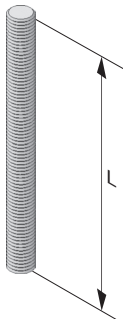

Extension Nut

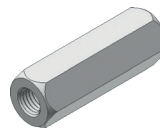

After installation of standard busbar 3000 mm lengths, you will be in need of special lengths which are smaller than 3000 mm. The minimum length for these special elements can be 350 mm. Please measure the lengths of these modules as shown below.







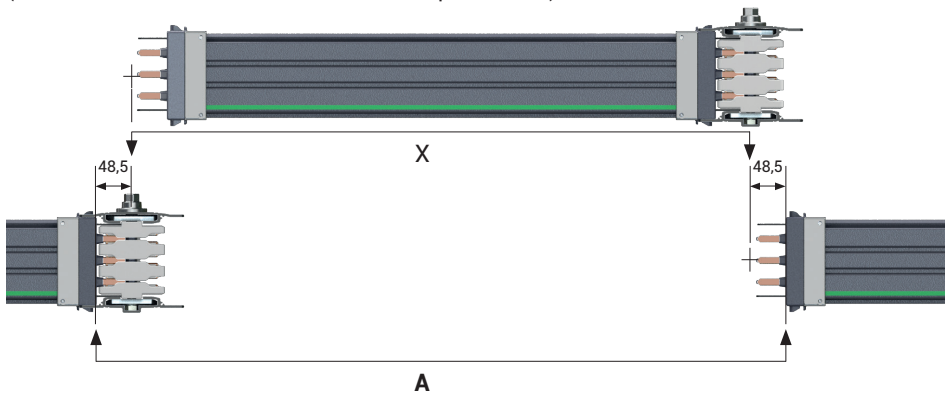

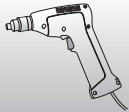
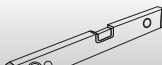

Length A is measured between housing of 2 busbars in mm. A. The special length is calculated by deducting 97 mm from this measured length.

$$X = A - 97 \text{ mm} \quad X = \text{Length of Special Busbar}$$

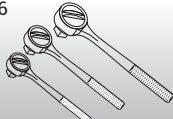
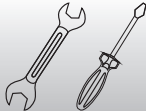
(The busbar module will be manufactured as per X value.)

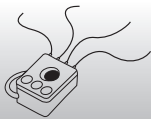

►► Equipment Used

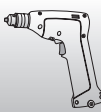
- | | | | | |
|---|--|--|---|---|
| 1

Fabric Crane Ropes | 2

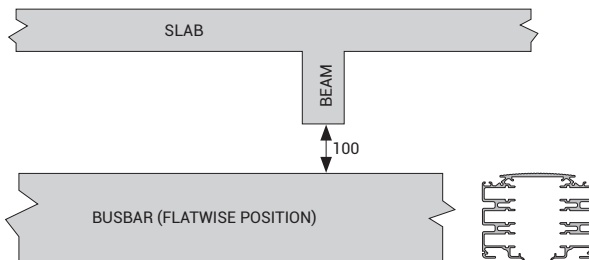
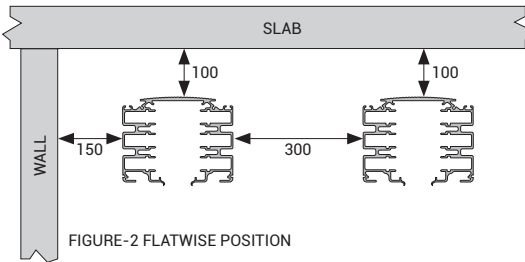
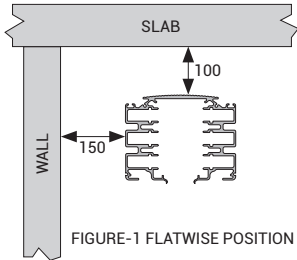
Torque Wrench | 3

Hot Air Blower | 4

Spirit Level | 5

Nut Set |
| 6

Socket Set | 7

Wrench, Screwdriver | 8

Lifting Device
(forklift truck, crane,
hoist etc.) | 9

Megger Device | 10

Dielectric Test Device
5 kV DC |
| 11

Scaffold | 12

Protective
Clothes,
Gloves, Goggles | 13

Drill | | |

* All dimensions in mm.



* All dimensions in mm.



CE DECLARATION OF CONFORMITY

Product Group E-Line KD Data Rack Busbar

Manufacturer EAE Elektrik Asansor End. Insaat San. ve Tic. A.S.
Akcaburgaz Mahallesi, 3114. Sokak,
No:10 34522 Esenyurt-Istanbul-Turkey

The objects of the declaration described below is in conformity with the relevant Union harmonisation legislation. This declaration of conformity is issued under the sole responsibility of the manufacturer.

Standard:

TS EN 61439-6

Low-voltage switchgear and controlgear assemblies - Part 6: Busbar trunking systems

IEC 61439-6

Low-voltage switchgear and controlgear assemblies - Part 6: Busbar trunking systems (busways)

CE - Directive:

2014/35/EU "The Low Voltage Directive"

2014/30/EU "(EMC) Electromagnetic Compatibility Directive"

2011/65/EU "RoHS Directive"

Technical Document Preparation Official:

EAE Elektrik Asansor End. Insaat San. ve Tic. A.S.
Akcaburgaz Mahallesi, 3114. Sokak, No:10 34522 Esenyurt-Istanbul

Mustafa AKÇELİK

Date

20.04.2025

Document Authorized Signatory

Elif Gamze KAYA OK
Deputy General Manager



Customer:		Date:/...../.....
Project:		Order No:
Address:		U_n : V	I_n : A
Busbar Code:		Material: AL <input type="checkbox"/> CU <input type="checkbox"/>	Conductor Section: x mm ²
Line:		Required Torque:	M12 83Nm
Note: The tests have to perform only with calibrated devices.			Calibration Date:/...../.....

Results

Junction :		Junction :		Junction :		Junction :		Junction :	
Phase	R (μΩ)	Phase	R (μΩ)	Phase	R (μΩ)	Phase	R (μΩ)	Phase	R (μΩ)
N - N		N - N		N - N		N - N		N - N	
L1 - L1		L1 - L1		L1 - L1		L1 - L1		L1 - L1	
L2 - L2		L2 - L2		L2 - L2		L2 - L2		L2 - L2	
L3 - L3		L3 - L3		L3 - L3		L3 - L3		L3 - L3	
PE - PE		PE - PE		PE - PE		PE - PE		PE - PE	
Torque: Nm	Torque: Nm	Torque: Nm	Torque: Nm	Torque: Nm
Max Value: μΩ	Max Value: μΩ	Max Value: μΩ	Max Value: μΩ	Max Value: μΩ

Junction :		Junction :		Junction :		Junction :		Junction :	
Phase	R (μΩ)	Phase	R (μΩ)	Phase	R (μΩ)	Phase	R (μΩ)	Phase	R (μΩ)
N - N		N - N		N - N		N - N		N - N	
L1 - L1		L1 - L1		L1 - L1		L1 - L1		L1 - L1	
L2 - L2		L2 - L2		L2 - L2		L2 - L2		L2 - L2	
L3 - L3		L3 - L3		L3 - L3		L3 - L3		L3 - L3	
PE - PE		PE - PE		PE - PE		PE - PE		PE - PE	
Torque: Nm	Torque: Nm	Torque: Nm	Torque: Nm	Torque: Nm
Max Value: μΩ	Max Value: μΩ	Max Value: μΩ	Max Value: μΩ	Max Value: μΩ

The maximum values per type and explanation to execute this test can be found in Annex A Electrical Site Tests of KD Manual

Remarks

Witnesses

Name	Company	Date	Signature

160A...1000A DATA RACK BUSBAR PRODUCT OVERVIEW (E-LINE KD)

1- Standards & Certification:

- Busbar system shall be designed and manufactured as per IEC 61439-6 standard, which requires below listed tests. Each busbar rating shall have a separate type test certificate from an independent internationally accredited laboratory including below tests: 10.2- Strength of material and parts, 10.2.2- Resistance to corrosion, 10.2.3- Properties of insulating materials, 10.2.3.1- Verification of thermal stability of enclosures, 10.2.3.2- Verification of resistance of insulating materials to abnormal heat and fire due to internal electric effects, 10.2.6- Mechanical impact, 10.2.7- Marking, 10.2.101- Ability to withstand mechanical loads, 10.2.101.1- Test procedure for a straight busbar trunking unit, 10.2.101.2- Test procedure for a joint, 10.2.101.3- Resistance of the enclosure to crushing, 10.3- Degree of protection of assembly, 10.4- Clearances and creepage distances, 10.5- Protection against electric shock and integrity of protective circuits, 10.5.2- Effective earth continuity between the exposed conductive parts of the assembly and the protective circuit, 10.5.3- Short-circuit withstand strength of the protective circuit, 10.9- Dielectric properties, 10.9.2- Power-frequency withstand voltage, 10.9.3- Impulse withstand voltage, 10.10- Verification of temperature rise, 10.11- Short-circuit withstand strength, Annex BB Phase conductor characteristics, Annex CC Fault-loop zero-sequences impedances, Annex DD Fault-loop resistances and reactances.
- Busbar system shall have CE marking.
- The manufacturer of busbar system shall have ISO 9001 and ISO 14001 certification.
- Each product shall have a "Type Label" including coding system, which identifies the brand, type of the unit, number of conductors and electrical details. The same coding shall be on the related certificate and catalogue.

2- Electrical Characteristics

- Busbar systems nominal insulation voltage shall be 1000 V.

2.1- Housing

- Conductors shall be packed and placed into the housing.
- Housing shall be made of thermal processed, extruded aluminium, RAL7012-Electrostatic painted.

2.2- Conductors

- Aluminium or Copper conductors overall isolated and tin plated.
- Aluminium conductors between 160A – 630A.
- Copper conductors between 250A – 1000A.
- Busbar system shall have the following number of conductors and wire configuration;
- 6 Conductors: (6 full size conductors CPE (100% earth conductor + double neutral + housing)),
- Phase conductors and neutral conductor shall have the same cross-section and they shall be insulated.
- Aluminium conductors shall be of EC grade aluminium. Minimum conductivity shall be 34m/mm².W.
- Copper conductors shall be minimum 99,95% electrolytic copper. Minimum conductivity shall be 56m/mm².W.

2.3- Insulation

- Insulation system shall be suitable for 1.000V continuous operation. Conductor size shall be designed so that temperature rise on the conductors shall not exceed 100°C degree at nominal current, which helps to global heating problem. With this reason, insulation class shall be selected as "B class".

2.4-Joint Structure

- Electrical and mechanical connection shall be made by placing conductor joints into the joint blocks of the connected conductors and followed by tightening and fastening of the joint bolts.

► Product Overview

2.5-Protection

- Protection degree of the housing and joints shall be IP23D.

2.6-Accessories

- Busbar system shall have all necessary accessories (elbows, panel-transformer connections, etc.)
Manufacturer shall supply special dimensioned units in short time, if the project conditions requires

3-Tap Off Boxes

- The Tap off boxes shall be Plug-nPlay type.
- Plug-n-Play tap off boxes shall be suitable to install or remove from busbars without switching off the power on the busbar.
- Plug-n-Play tap off boxes shall be suitable to install or remove anywhere alongside the busbar.
- The Tap-Off Box contacts shall be protected with a cover
- The Tap-Off contacts shall be heat cycle tested
- Contacts of plug-in tap off box shall be silver plated.
- The special locking mechanism of the Tap-Off Boxes shall ensure to carry the weight of the plug-in box and cables by the busbar housing
- While inserting the contacts of plug-in tap off box, earth contact shall make the first touch. While removing, it shall be disconnected last.
- Tap off boxes shall be manufactured of epoxy painted aluminium.
- The Tap-Off Boxes shall be equipped with a safe alignment mechanism to ensure correct installation and operation

4-Busbar Fixing&Mounting System

- The Busbars shall be easily installed and positioned through their entire lengths with the "Snap-In Fixing Units" by inserting into the guiding slots on top of the housing.
- To ensure flexible positioning of the Busbars, each single busbar length shall easily slide independently on the "Snap-In Fixing Units" through the guiding slots.
- To maintain the mounting security, the "Snap-In Fixing Unit" clamps shall be lockable.
- For various mounting practices the "Snap-In Fixing Units" shall be available with threaded rod, ceiling support and/or with tray brackets options

5-Installation and Commissioning

- Busbar systems shall be installed as per Single-Line drawings respect to required ampere rates and manufacturer installation guide (torque values, lockers, etc.). Electrical installer shall run an insulation test after installation, according to manufacturer's test procedures. The results of the test shall be reported to the manufacturer and minimum insulation value shall be 1 Mohms.

PRODUCT TYPES



BUSBAR ENERGY DISTRIBUTION SYSTEMS



CABLE TRAYS



TROLLEY BUSBAR ENERGY DISTRIBUTION SYSTEMS



INDOOR SOLUTIONS



SUPPORT SYSTEMS

Please visit our website for the updated version of our catalogues.
www.eaelectric.com



EAE Elektrik A.S.
Head Office
Akcaburgaz Mahallesi,
3114. Sokak, No:10 34522
Esenyurt - Istanbul - TURKEY
Tel: +90 (212) 866 20 00
Fax: +90 (212) 886 24 20

EAE DL 3 Factory
Busbar
Gebze IV Istanbul Makine ve
Sanayicileri
Organize Bolgesi, 6. Cadde,
No: 6 41455 Demirciler Koyu,
Dilovası - Kocaeli - TURKEY
Tel: +90 (262) 999 05 55
Fax: +90 (262) 502 05 69



KD Manual 55-Eng. / Rev 03 000 Pcs. 0.Pcs. 22.04.2026
D.S.

EAE has full right to make any revisions or changes on this catalogue without any prior notice.

